



TECHNICAL MANUAL

MICROWAVE LINK

10-13 GHz

Address : Via Selaschi 42
16040 Leivi (Ge) - ITALY
Telephone : +39 (0185) 35 13 33
Fax : +39 (0185) 35 13 00
http : www.elber.it
e-mail : elber@elber.it

02/JAN/07
EDITION

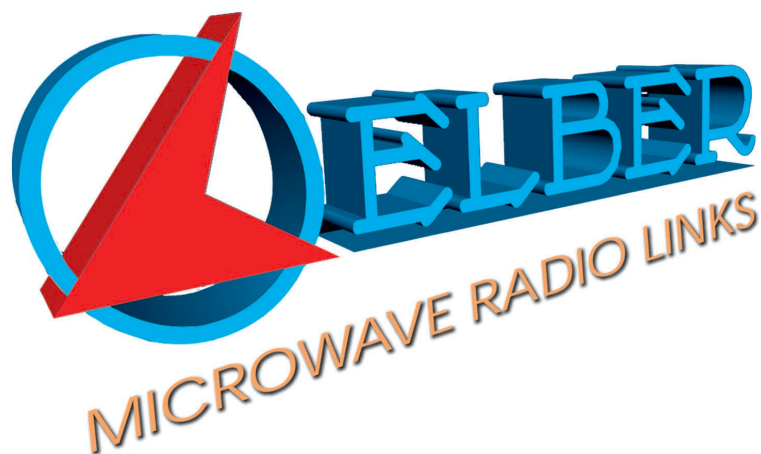

General Information for Technical Personnel

Congratulations for using ELBER Microwave Radio Links!

This equipment was manufactured by qualified technicians and has been developed with high level technology according to the ECC regulations.

This product has a modular structure in order to facilitate the maintenance and control; modules and connectors can be removed and replaced.

Our company has been working in the broadcast market for more than twenty years, manufacturing analog and digital Microwave Radio Links. ELBER has sold more than 3,500 equipments in Italy and overseas, consolidating its own trademark with Microwave Links of high quality.

This technical manual will help you getting a good performance with ELBER Microwave Radio Links. The following chapters contain circuit description, components layout and other specific information. If you have any questions after reviewing this manual please feel free to contact us. We are dedicated to supporting our customers.

Thank you for using ELBER equipments.

ELBER S.r.l.
Technical Department

Visit our Web site! <http://www.elber.it>

INDEX

Microwave Link 10-11-12-13 GHz

General transmitter descriptions
Transmitter unit layout
General receiver descriptions
Receiver unit layout
Technical specifications

TRANSMITTER UNIT

MODULATOR

1. Meter module - transmitter
2. Audio modulator 3/4
3. Audio modulator 1/2
4. Video combiner
5. IF-modulator

TRANSMITTER

6. Local oscillator
7. Up converter
8. Amplifier 1W
9. Power amplifier 4W
10. Power supply unit

RECEIVER UNIT

DEMODULATOR

11. Meter module - receiver
12. Audio demodulator 3/4
13. Audio demodulator 1/2
14. Video separator
15. IF- discriminator

RECEIVER

16. IF-module
17. Local oscillator
18. Down converter
19. Power supply unit

TRANSMITTER TMC/10

The transmitter TMC/10 has been designed to convert a 70 MHz IF signal to a microwave frequency of 10-11-12-13 GHz and amplify it to 1 Watt. The configuration is a single frequency conversion. The modulations allowed are analogue or digital.

The main function in analogue modes is transmitting a FM modulated carrier by a TV signal with audio subcarrier.

In digital mode, the transmitter carries a modulated IF signal.

The receiving equipment is ELBER R/10.

The apparatus cabinet is a standard rack 19" 4U in modular version, which increases the versatility and makes maintenance and control much easier.

The analogue modulator can be inserted (OPT MOD70) in the same rack .

In this configuration the transmitter will have in input the BASE BAND signal or the VIDEO & AUDIO (2 or 4 channels) separately.

The transmitter can be powered either at AC 230/110V 50/60Hz or DC 24V negative to ground with automatic switching between this two in case of failure (option DC 20-72V positive to ground)

Normally, the output flange is placed on the front panel, but on request it can be on the rear.

The transmitter also has:

- a) an output 4 cells branching filter
- b) a display that shows:
 - the output power,
 - the supply voltage and
 - the audio and video modulation levels (in case OPT MOD 70)

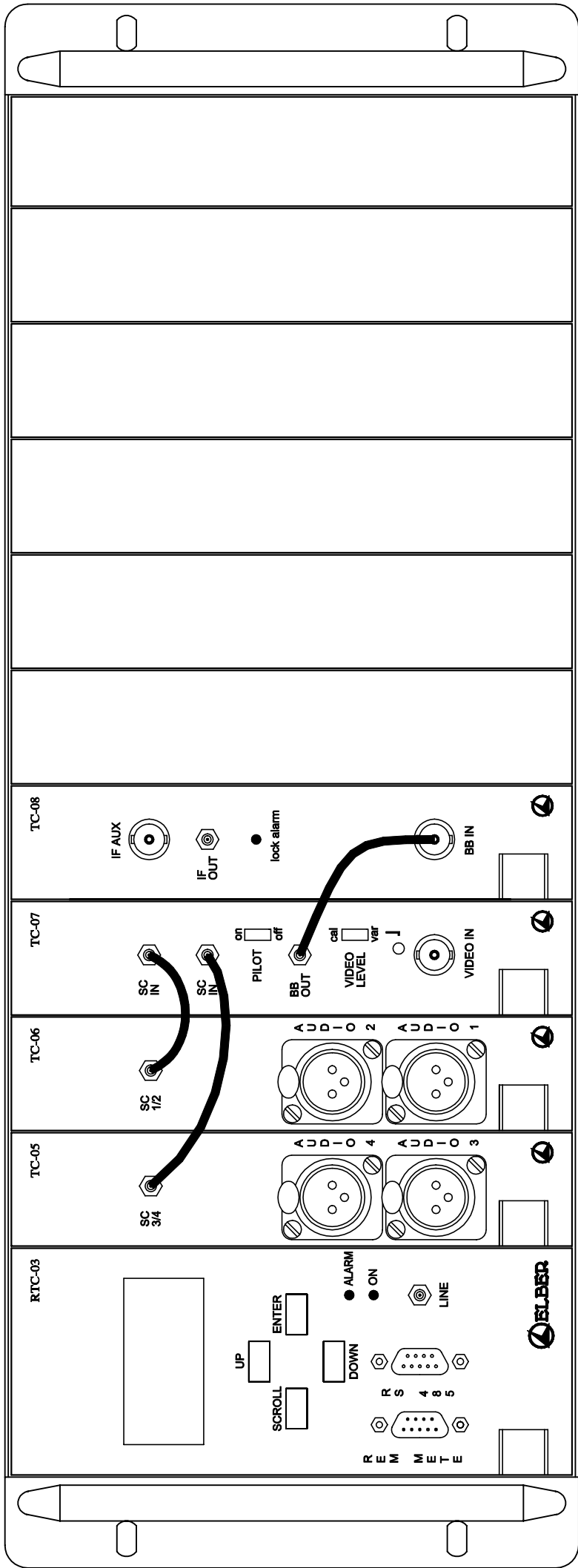

DATE
10-FEB-03

DESCRIPTION
MOD 70 - 4 AUDIO

DRAWING CODE
XX-116-FW

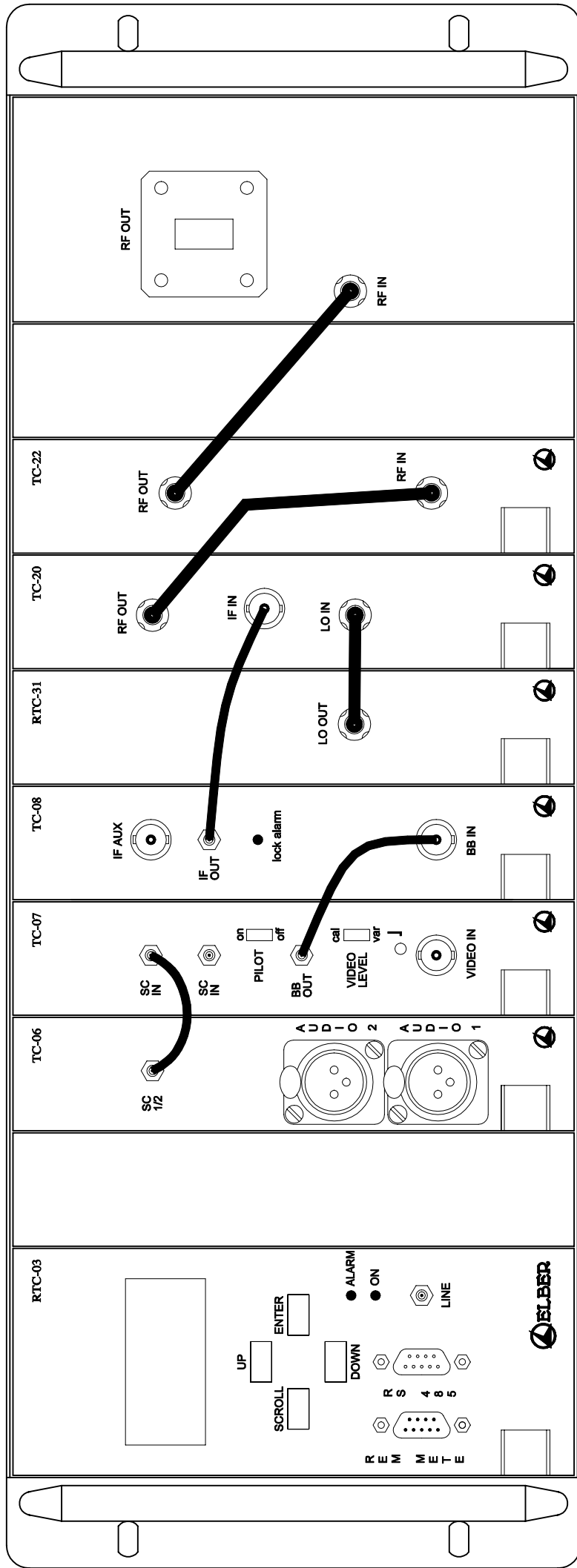

		DATE	DESCRIPTION	DRAWING CODE
		10-FEB-05	TX 10-12-13GHz - 1 W 2 AUDIO	XX-211-FW

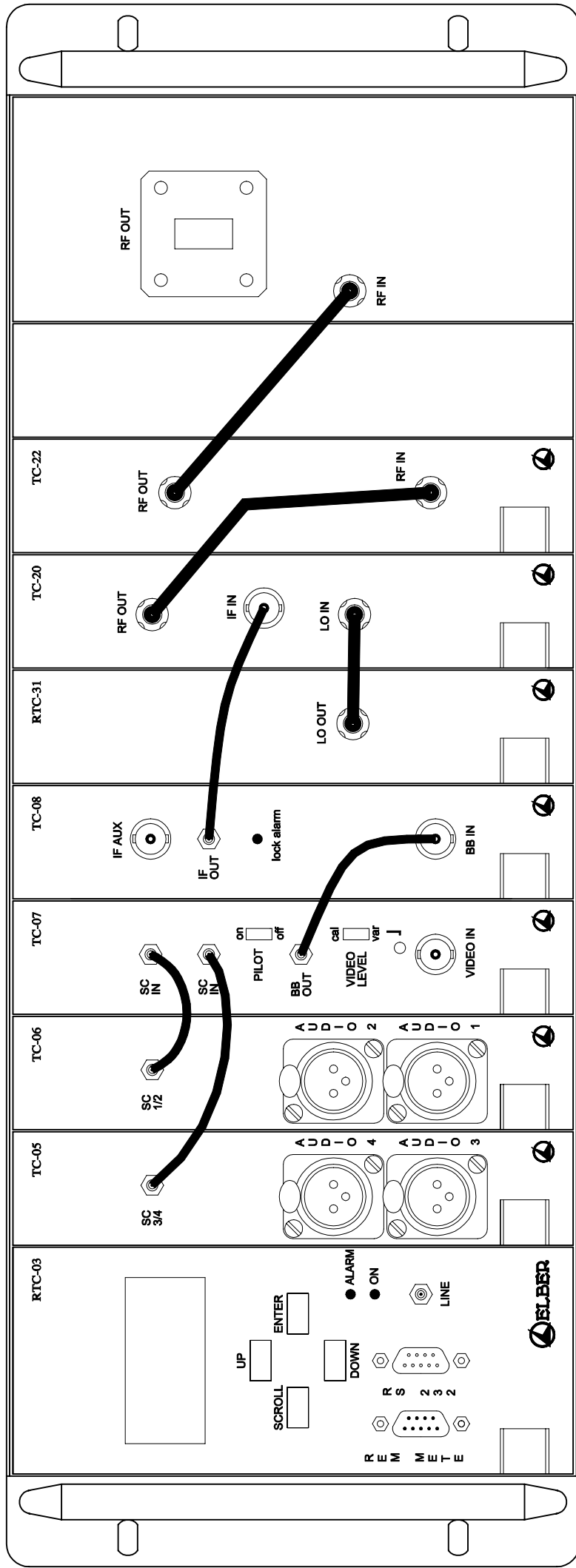

	DATE	DESCRIPTION	DRAWING CODE
	10-FEB-05	TX 10-12-13GHZ - 1 W 4 AUDIO	XX-212-FW

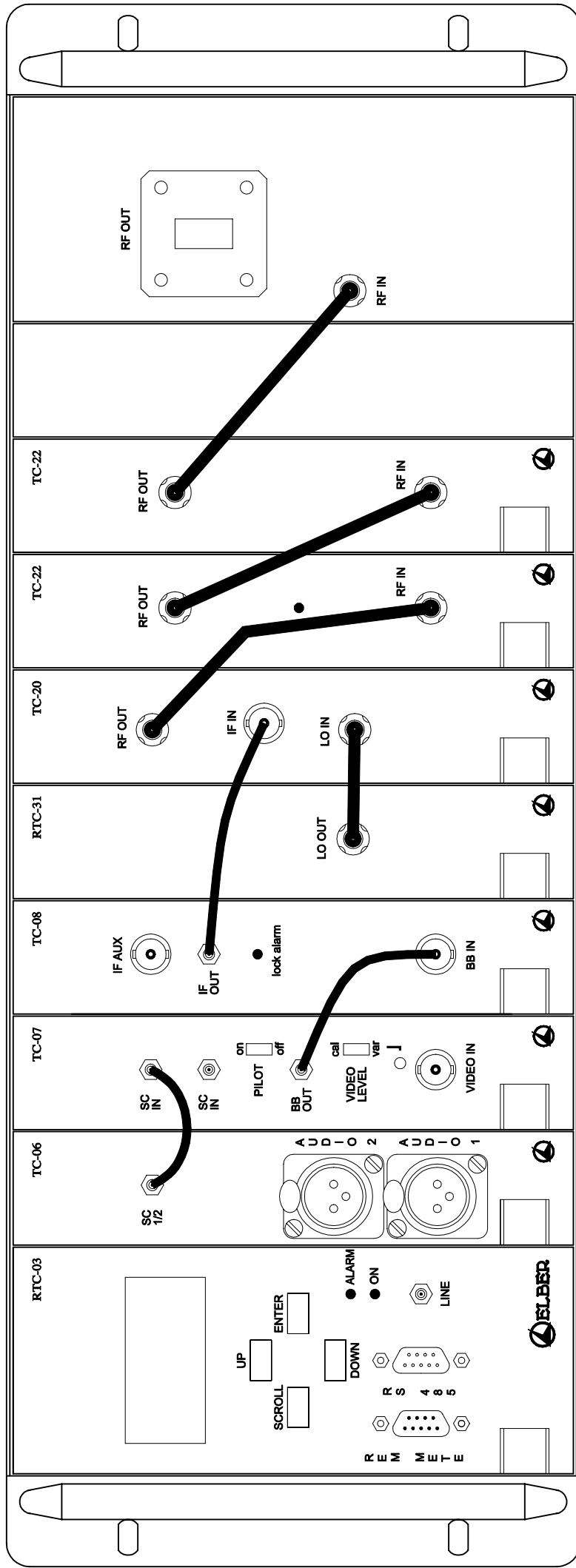

	DATE	DESCRIPTION	DRAWING CODE
	10-FEB-05	TX 10-12-13GHZ - 4 W 2 AUDIO	XX-213-FW

RECEIVER R/10

The receiver R/10 has been designed to convert a 10-11-12-13 GHz microwave signal to 70MHz IF and amplify it to a nominal output level.

The configuration is a single frequency conversion. The modulations allowed are analogue or digital.

The transmitting equipment is ELBER TMC/10.

The apparatus cabinet is a standard rack 19" 4U in modular version, which increases the versatility and makes maintenance and control much easier.

The analogue demodulator (OPT DEM70) can be inserted in the same rack .

In this configuration, apart from the IF signal at the output, the receiver also returns the BASE BAND signal , VIDEO & AUDIO (2 or 4 channels) separately.

The receiver can be powered either at AC 230/110V 50/60Hz or DC 24V negative to ground with automatic switching between this two in case of failure (option DC 20-72V positive to ground)

Normally, the output flange is placed on the front panel, but on request it can be on the rear.

The receiver also has:

- a) an input 5 cells branching filter
- b) a display that shows:
 - the input RF level,
 - the supply voltage

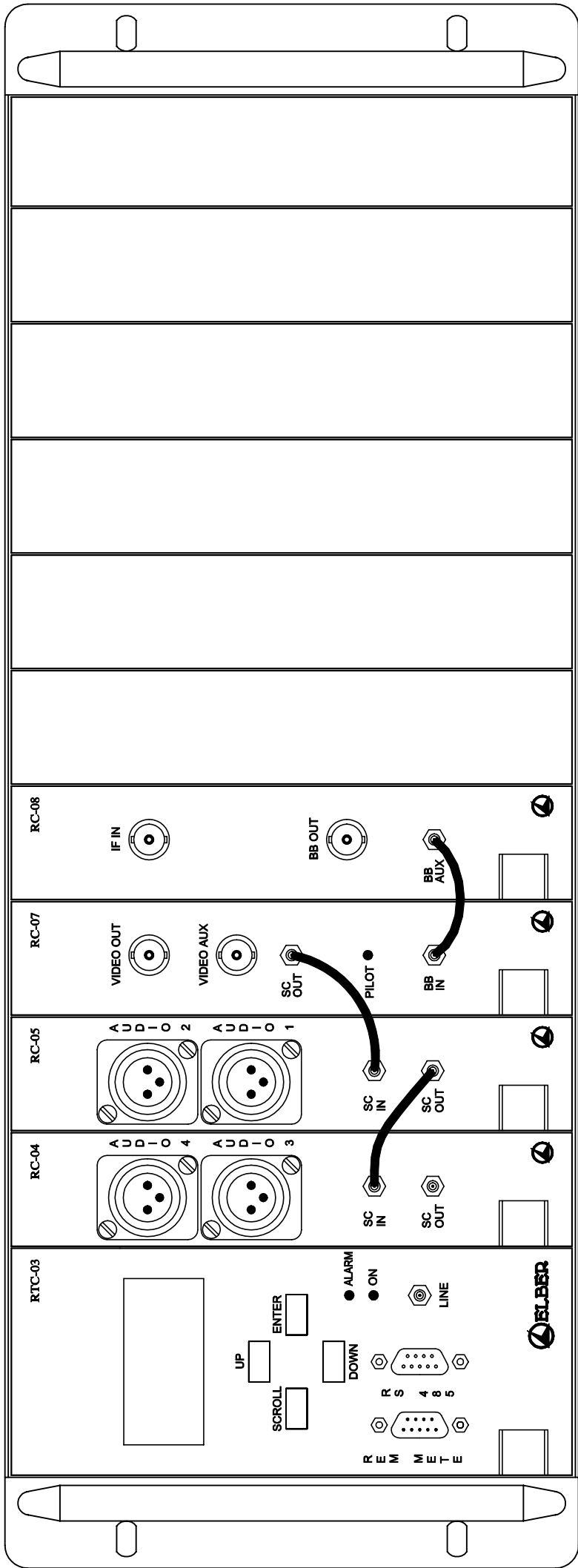

ELBER	DATE	DESCRIPTION	DRAWING CODE
	10-FEB-03	DEM 70 - 4 AUDIO FRONT VIEW	XX-128-FW

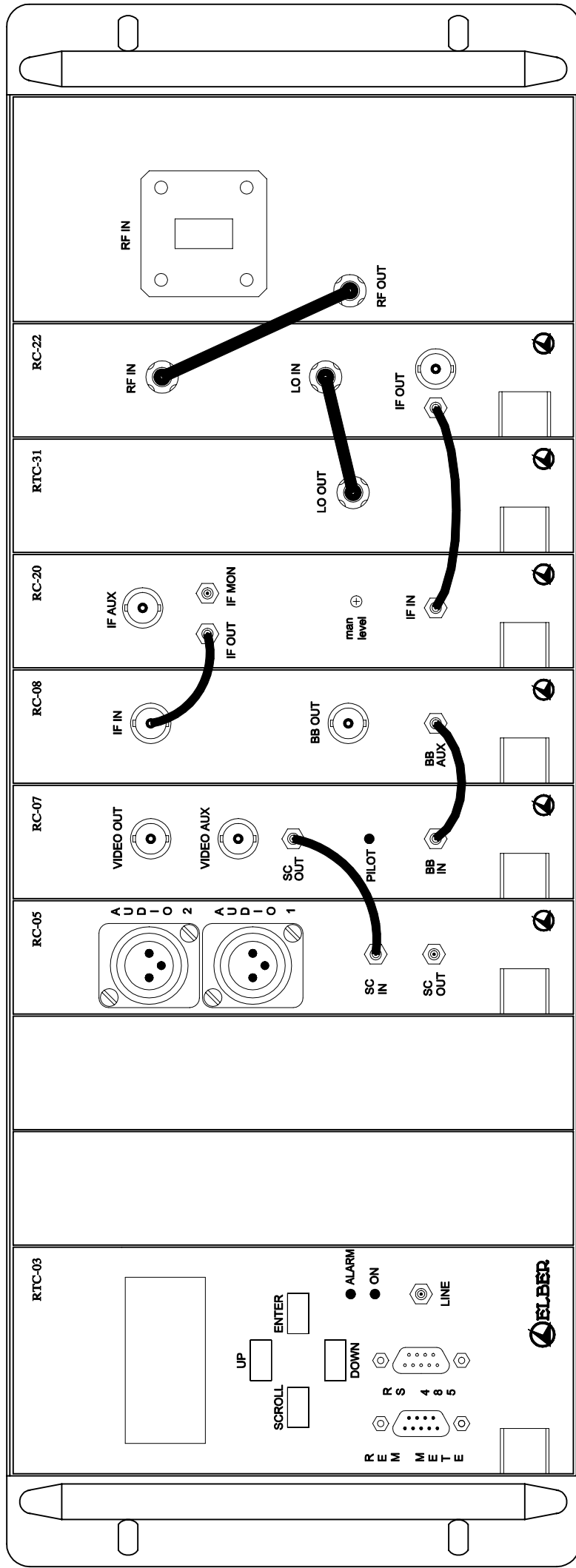

	DATE	DESCRIPTION	DRAWING CODE
	10-FEB-05	RX 10-12-13GHZ - 2 AUDIO FRONT VIEW	XX-214-FW

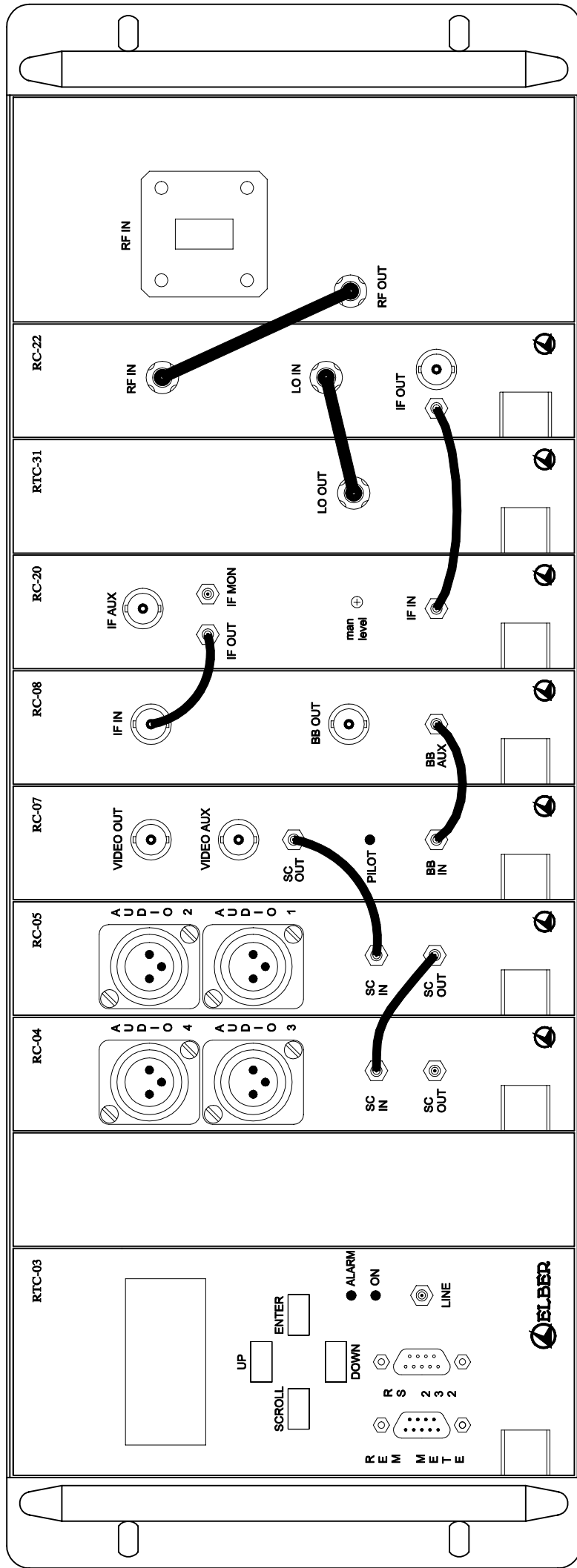

	DATE	DESCRIPTION	DRAWING CODE
	10-FEB-05	RX 10-12-13GHZ - 4 AUDIO FRONT VIEW	XX-215-FW

MOD 70 - OPT MOD70 - MOD-SL SPECIFICATIONS

MODULATOR SPECIFICATIONS

CENTER FREQUENCY	70 MHz +/- 5 KHz
OUTPUT IMPEDANCE	75 OHM
OUTPUT LEVEL	+5 dBm +/- 1.5 dB
OUTPUT RETURN LOSS	< -28 dB
OUTPUT CONNECTOR	" BNC " Female

BASE BAND SPECIFICATIONS

INPUT LEVEL (For Df=8 MHz pp at 1512 KHz)	1 Vpp
BANDWIDTH (ripple < 1dBpp)	40 Hz / 10 MHz
INPUT RETURN LOSS	< -28 dB
INPUT CONNECTOR	" BNC " Female

VIDEO SPECIFICATIONS

INPUT LEVEL	1 Vpp
BANDWIDTH	40 Hz / 6 MHz
PREEMPHASIS	CCIR 405 -1
DIFFERENTIAL GAIN	< 1%
DIFFERENTIAL PHASE	< 1°
WEIGHTED S/N	> 70 Db
GROUP DELAY (40 Hz / 6 MHz)	< 10 nSec
INPUT RETURN LOSS	< -28 dB
INPUT CONNECTOR	" BNC " Female

AUDIO SPECIFICATIONS

NUMBER OF AUDIO CHANNELS	2 - 4
INPUT LEVEL	+9 dBm
INPUT IMPEDANCE (balanced)	600 OHM /15KOHM
PREEMPHASIS	50 usec
SUBCARRIERS DEVIATION	70 KHz rms
BANDWIDTH	30 Hz /15KHz
SUBCARRIER FREQUENCIES (KHz)	Audio 1 = 7500 , Audio 2 = 8065 Audio 3 = 7020 , Audio 4 = 8590
TOTAL HARMONIC DISTORTION	< 0.3 %

GENERAL SPECIFICATIONS

POWER REQUIREMENTS	AC 230V/110V 50/60 Hz DC 20-30V negative to ground (Option 20 ÷ 60V GND isolated)
POWER CONSUMPTION	20 W
CABINET Model MOD70	Rack 19" 4U
DIMENSIONS Model MOD70	Width 482 mm. Height 177 mm. Depth 330 mm
CABINET Model MOD-SL	Rack 19" 1U
DIMENSIONS Model MOD-SL	Width 482 mm. Height 44 mm. Depth 475 mm.

TRANSMITTER 10 - 11 - 12 - 13 GHz

TRANSMITTER SPECIFICATIONS

FREQUENCY BAND Model TMC/10	10.2 - 10.7 GHz 10.7 - 11.5 GHz 11.7 - 12.4 GHz 12.7 - 13.2 GHz
RF OUTPUT POWER	+ 30 dBm + / - 1 dB + 36 dBm + / - 1 dB
RF OUTPUT CONNECTOR (FRONT or REAR)	IEC UBR 120
RF OUTPUT RETURN LOSS (@ +/- 10 MHz)	< -26 dB
SPURIOUS OUTPUT CONTENT	< - 80 dB
IF IMPEDANCE	75 OHM
IF INPUT LEVEL	+5 dBm +/-1.5 dB
IF INPUT RETURN LOSS	< -26 dB
IF INPUT CONNECTOR	" BNC " Female
FREQUENCY STABILITY	< + / - 20 ppm
AMPLITUDE/FREQUENCY FLATNESS (@ +/- 10 MHz)	< 0.25 dB
GROUP DELAY (@ +/- 10 MHz)	< 2.5 nsec

GENERAL SPECIFICATIONS

POWER REQUIREMENTS	AC 230V/110V 50/60 Hz DC 20-30V negative to ground (Option 20 ÷ 60V GND isolated)
POWER CONSUMPTION (+30dBm)	30 W
POWER CONSUMPTION (+36dBm)	40 W
CABINET	Rack 19" 4U
DIMENSIONS	Width 482 mm. Height 177 mm. Depth 330 mm.

RECEIVER 10 - 11 - 12 - 13 GHz

RECEIVER SPECIFICATIONS

FREQUENCY BAND Model R/10	10.2 - 10.7 GHz 10.7 - 11.5 GHz 11.7 - 12.4 GHz 12.7 - 13.2 GHz
RF INPUT CONNECTOR	IEC UDR 120
RF INPUT RETURN LOSS (@ +/- 10 MHz)	< - 26 dB
NOISE FIGURE	< 5 dB
RF SELECTIVITY	< - 10 dB @ +/- 40 MHz
IMAGE REJECTION	< - 80 dB
IF IMPEDANCE	75 OHM
IF OUTPUT RETURN LOSS	< - 26 dB
IF OUTPUT CONNECTOR	" BNC " Female
OUTPUT LEVEL	+ 5 dBm +/-1.5 dB
FREQUENCY STABILITY	< +/- 20 ppm
AMPLITUDE/FREQUENCY FLATNESS (input level -25 dBm / -75 dBm)	< 0.25 dB
GROUP DELAY (@ +/- 10 MHz)	< 2.5 nsec

SYSTEM PERFORMANCE

IF / IF LOOP

RECEIVER INPUT LEVEL	-30 dBm / -75 dBm
AMPLITUDE/FREQUENCY FLATNESS (58MHz / 82MHz)	< 0.5 dB
GROUP DELAY DISTORTION (60MHz / 80 MHz)	< 3 nsec

BB / BB LOOP (MODEM + LINK)

AMPLITUDE /FREQUENCY FLATNESS	25Hz - 5 MHz < +/- 0.5 db 5MHz - 9.1MHz < +/- 1dB
INPUT / OUTPUT IMPEDANCE	75 OHM
INPUT / OUTPUT RETURN LOSS	< -28 dB

VIDEO / VIDEO LOOP (MODEM + LINK)

VIDEO LEVEL	1Vpp
INPUT / OUTPUT IMPEDANCE	75 OHM
INPUT / OUTPUT RETURN LOSS	< -28dB
AMPLITUDE /FREQUENCY FLATNESS	< 0.5 dB
DIFFERENTIAL GAIN	< 1%
DIFFERENTIAL PHASE	< 1°
S/N RATIO (weighted 10 KHz - 5MHz)	< - 70 dB
S/N RATIO (0 - 10 KHz)	< -65 dB
BAR LUM. AMPL.	< 1%
BASE LINE DISTORT.	< 1%
TILT	< 1%

2T AMPLITUDE	< 1%
LINE TIME NONLINEARITY	< 1%
COLOR SUBCARRIER	< 5%
INTERMODULATION	< 1%
COLOR SUBCARRIER 20T	< 5%
INTERMOD 20T	< 1%
CROMIN / LUMIN DELAY	< 3 nsec
VIDEO GROUP DELAY	< 10 nsec
SYNC PULSE AMPLITUDE	< 1%
BURST AMPLITUDE	< 5%

GENERAL SPECIFICATIONS

POWER REQUIREMENTS	AC 230V/110V 50/60 Hz DC 20-30V negative to ground (Option 20 ÷ 60V GND isolated)
POWER CONSUMPTION	20 W
CABINET DIMENSIONS	Rack 19" 4U Width 482 mm. Height 177 mm. Depth 330 mm.

DEM 70 – OPT DEM70 - DEM-SL SPECIFICATIONS

BASE BAND SPECIFICATIONS

OUTPUT LEVEL (For $\Delta f=8$ MHz pp at 1512 KHz)	1 Vpp
BANDWIDTH (ripple < 1dBpp)	40 Hz / 10 MHz
OUTPUT RETURN LOSS	< -28 dB
OUTPUT CONNECTOR	" BNC " Female

VIDEO SPECIFICATIONS

OUTPUT LEVEL	1 Vpp
BANDWIDTH	40 Hz / 6 MHz
PREEMPHASIS	CCIR 405 -1
DIFFERENTIAL GAIN	< 1%
DIFFERENTIAL PHASE	< 1°
WEIGHTED S/N	> 70 Db
GROUP DELAY (40 Hz / 6 MHz)	< 10 nSec
OUTPUT RETURN LOSS	< -28 dB
OUTPUT CONNECTOR	" BNC " Female

AUDIO SPECIFICATIONS

NUMBER OF AUDIO CHANNELS	2 - 4
INPUT LEVEL	+9 dBm
INPUT IMPEDANCE (balanced)	50 OHM /600 OHM
PREEMPHASIS	50 usec
BANDWIDTH	30 Hz /15KHz
SUBCARRIER FREQUENCIES (KHz)	Audio 1 = 7500 , Audio 2 = 8065 Audio 3 = 7020 , Audio 4 = 8590
TOTAL HARMONIC DISTORTION	< 0.3 %

GENERAL SPECIFICATIONS

POWER REQUIREMENTS	AC 230V/110V 50/60 Hz DC 20-30V negative to ground (Option 20 ÷ 60V GND isolated)
POWER CONSUMPTION	20 W
CABINET Model DEM70	Rack 19" 4U
DIMENSIONS Model DEM70	Width 482 mm. Height 177 mm. Depth 330 mm
CABINET Model DEM-SL	Rack 19" 1U
DIMENSIONS Model DEM-SL	Width 482 mm. Height 44 mm. Depth 475 mm



Transmitter Unit

TABLE OF CONTENTS

1 METER RTC-03	A
1.1 FRONT PANEL CONTROL	A
1.2 CONFIGURING THE METER	C
1.3 TRANSMITTER MAIN MENU OPTIONS	E
1.3.1 TRANSMITTER CONFIGURATION	F
1.3.2 TRANSMITTER STATUS	F
1.4 RECEIVER MAIN MENU OPTIONS	G
1.4.1 RECEIVER CONFIGURATION	G
1.4.2 RECEIVER STATUS	H
1.5 RS-485	H
1.6 REM METER	H

1 METER RTC-03

The RTC-03 manages and controls all communication performed within the equipment being analogue modulator/demodulator, transmitter or receiver. All controls are performed using the four way keypad and the LCD on the front panel. In addition, the RTC-03, displays status messages and parameter settings for installed modules. These parameters, apart from being displayed on the LCD, can also be accessed remotely via RS485 connection. The RF power (for a transmitter) or RF Field (for a receiver) also can be remotely accessed via an analogue signal.

1.1 FRONT PANEL CONTROL

<i>Control Item</i>	<i>Description</i>			
LCD	The LCD is a 12*2 alphanumeric display used to present all control and status messages from the embedded system.			
Four Way Keypad	The Four Way Keypad enables navigation through the various menus of the embedded system. Unless stated otherwise, the function of the keypad is as follows:			
	<i>Keypad</i>	<i>Configuration Menu</i>		<i>Status Menu</i>
		<i>Cursor Position 1</i>	<i>Other Cursor Position</i>	
	UP	Previous Menu	Increase Value	Previous Menu
DOWN	Next Menu	Decrease Value	Next Menu	

	SCROLL	Moves Cursor's Position one step to the right	Scrolls cursor's position one step to the right. If Position scrolls back to Position 1 any changes will be discarded and original values will be reloaded	Not used
	ENTER	Next Menu	Saves changes	Next Menu
REM METER	For pinout please refer to section 1.6			
RS485	For pinout please refer to section 1.5			
LINE	The LINE output is used to control Elber's External RF Head Units			
ALARM	The ALARM led can have two states: <ul style="list-style-type: none"> • OFF: No Alarm Present • ON: Some values are outside normal operation range. Please go through menus to check error. 			
ON	When the ON led is green, it indicates that the RTC-03 is switched on.			

1.2 CONFIGURING THE METER

Prior to use the RTC-03 for the first time, it is important to configure the system parameters depending on the modules installed. In order to access the Advanced Menu, please follow this simple procedure:

With the equipment switched off, press and hold the UP and DOWN buttons simultaneously. With the buttons still pressed, switch on the equipment until the display shows :

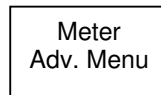

The hierarchy of the Advanced menu is shown in Figure 1.

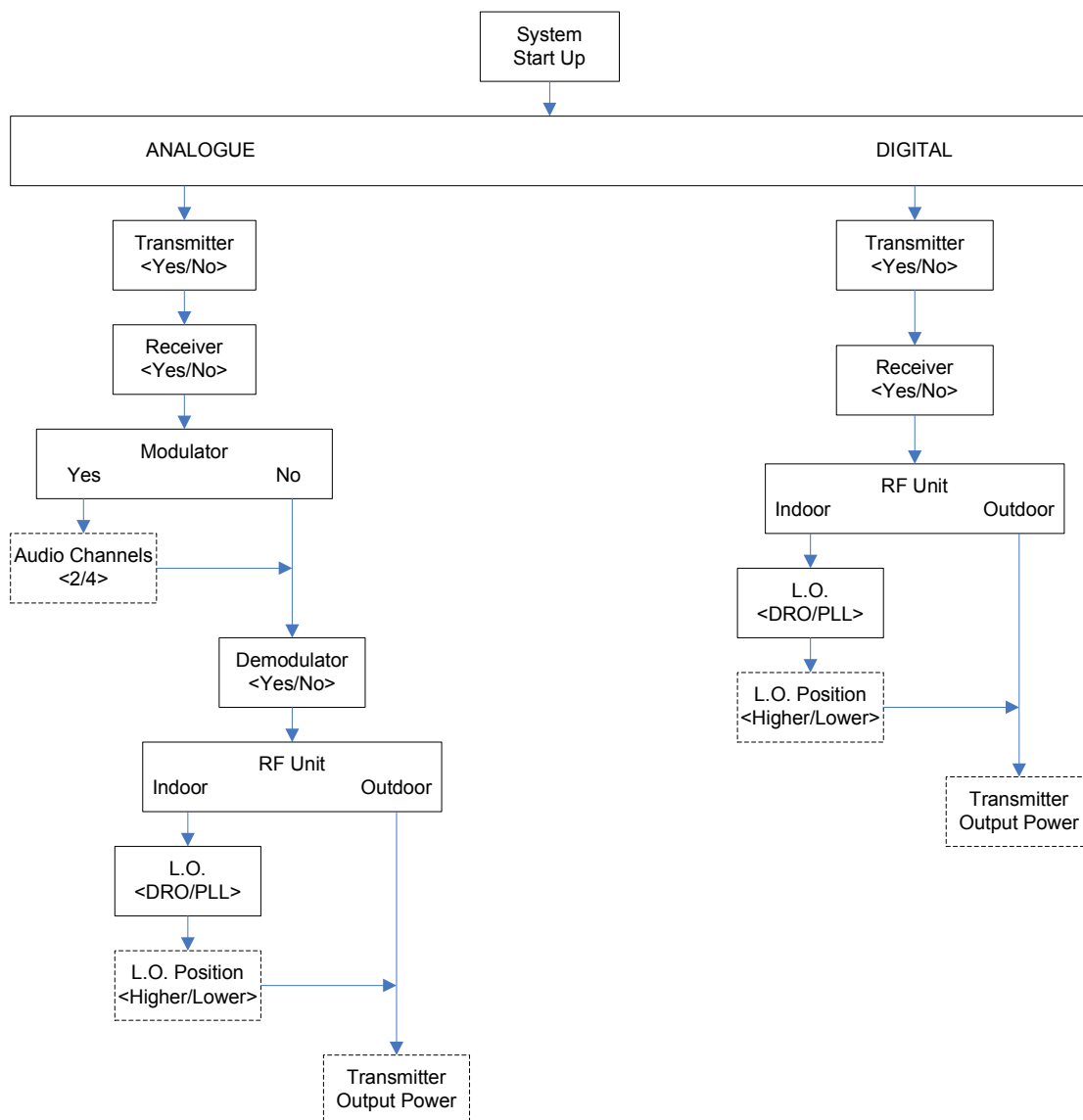

Figure 1: Tree of Advanced Menu

(Dotted menu indicates that availability of the option is dependent on the system parameters)

The navigation through menus is based on type of equipment meter needs to control, i.e. either analogue or digital.

Explanation of each menu follows:

Menu	Description
Transmitter <Yes/No>	Choose YES if equipment is a Transmitter, else choose NO.
Receiver <Yes/No>	Choose YES if equipment is a Receiver, else choose NO.
Modulator <Yes/No>	This menu item is only available for ANALOGUE equipment. Choose YES if equipment has Modulator installed, else choose NO.
Demodulator <Yes/No>	This menu item is only available for ANALOGUE equipment. Choose YES if equipment has Demodulator installed, else choose NO.
Audio Channels <2/4>	Choose 2 if Analogue Modulator has 2 Audio Channels installed else choose 4.
RF Unit <Indoor/Outdoor>	This parameter indicates type of RF head used, either Indoor (i.e. a single rack) or Outdoor (i.e. two separate racks connected via IF signal).
L.O. <DRO/PLL>	The Local Oscillator installed can either be free-running or synthesized. Choose: DRO if its free-running, and PLL if local oscillator if synthesized
L.O. Position <Higher/Lower>	Local Oscillator can either be Higher or Lower to the Microwave Radio Link's Frequency.
Transmitter Output Power	Transmitter's Nominal Output Power should be selected from available levels in order to display the correct value of output power.

On exiting the Advanced Menu, the user will be asked whether or not he wants to save changes performed. Choosing YES all new values for system parameters are saved, otherwise all changed values are discarded and previous system parameters are reloaded. The system parameters are stored on an external EEPROM.

After switching on the equipment and the system is ready from the initial tests and configuration, the equipment will present the Main Status Display on the LCD.

1.3 TRANSMITTER MAIN MENU OPTIONS

The hierarchy of the Transmitter's Main menu is shown in Figure 2.

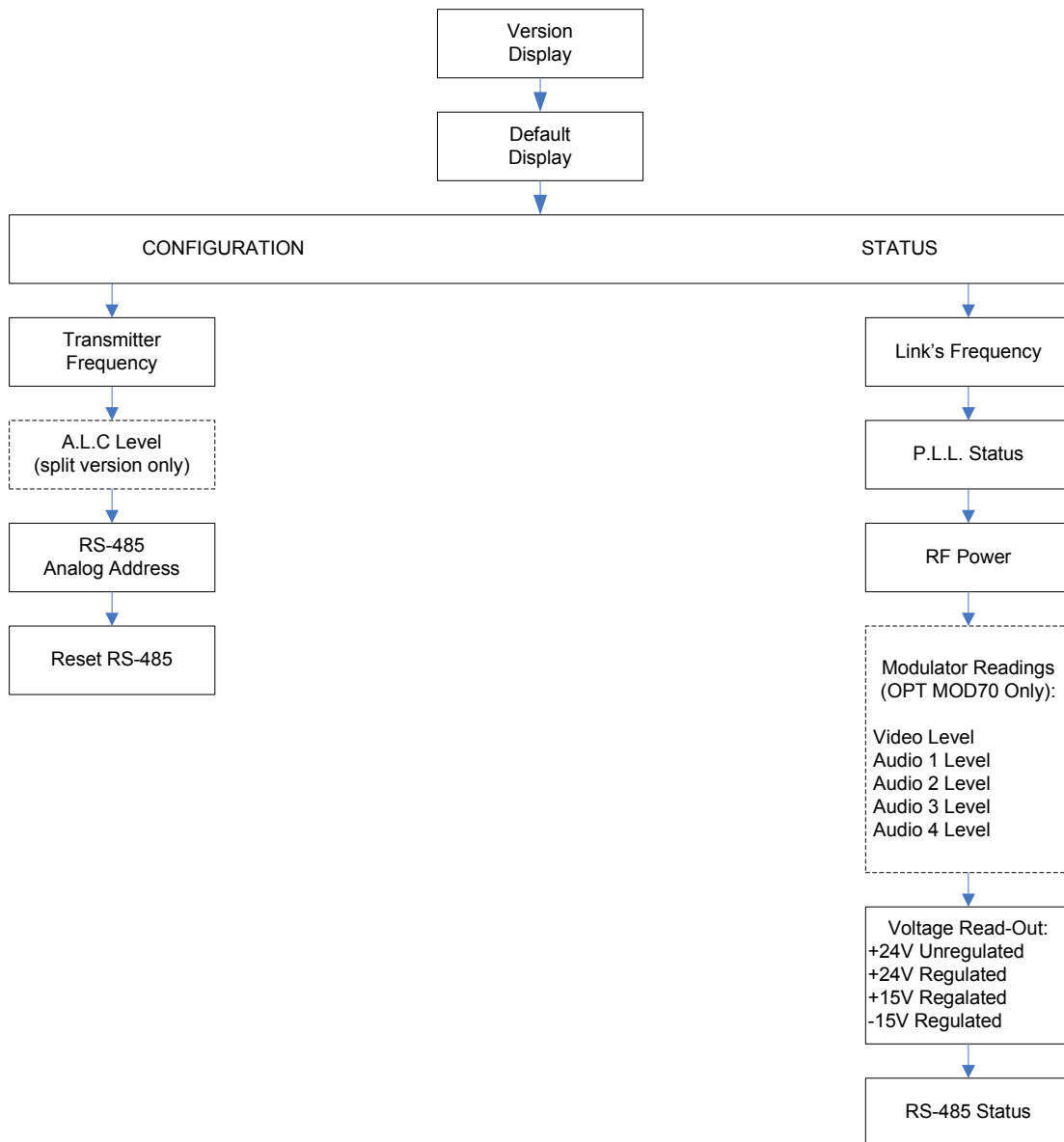

Figure 2: Tree of Transmitter Main Menu

Explanation of each menu follows:

1.3.1 TRANSMITTER CONFIGURATION

Menu	Description
Transmitter Frequency	The frequency of Transmitter can be changed within predefined limits
ALC level (split version only)	The value of back-off for the output power can be changed (0÷15 dB)
RS-485 analog address	Antenna Nord Protocol The value for the RS-485 address ranges from 1 to 32 can be changed
Reset RS-485	Reset counter of the communication errors on RS-485

1.3.2 TRANSMITTER STATUS

Menu	Description
Link's frequency	The frequency of apparatus is displayed
P.L.L. Status	Status: LOCK: P.L.L. Locked UNLOCK: P.L.L. Unlocked N/A: Communication with P.L.L. lost
RF power	The RF power of apparatus is displayed
Modulator Readings (OPT MOD70 only)	These menus display: Video Level Power Audio 1 Level Power Audio 2 Level Power Audio 3 Level Power Audio 4 Level Power
Voltage Read-Out	The operating voltages of apparatus are displayed
RS-485 Status	A summary of address in use, communication and parity errors is displayed

1.4 RECEIVER MAIN MENU OPTIONS

The hierarchy of the Receiver's Main menu is shown in Figure 3.

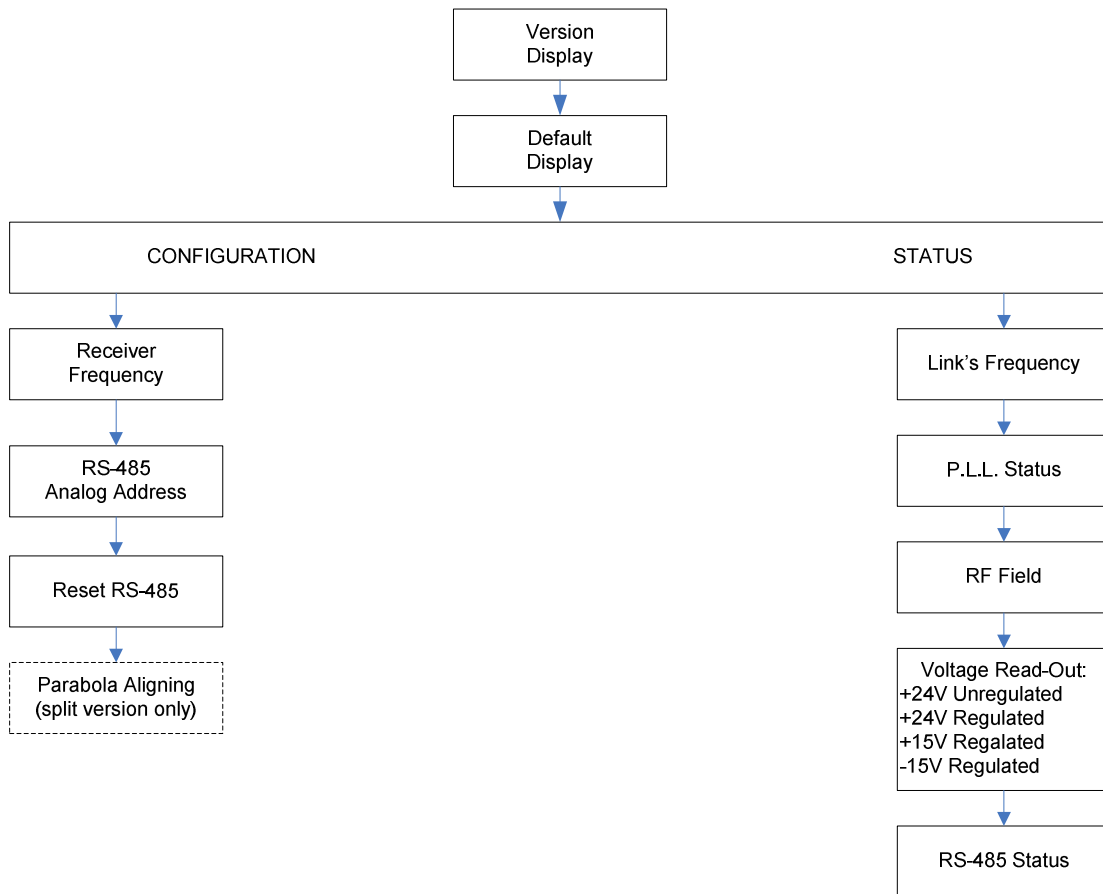

Figure 3: Tree of Receiver Main Menu

Explanation of each menu follows:

1.4.1 RECEIVER CONFIGURATION

Menu	Description
Receiver Frequency	The frequency of Receiver can be changed
RS-485 analog address	Antenna Nord Protocol The value for the RS-485 address ranges from 1 to 32 can be changed
Reset RS-485	Reset counter of the communication errors on

	RS-485
Parabola Aligning (Split version only)	Continuous refresh of Receiver's RF field in split version is performed. Press Enter to exit from this menu

1.4.2 RECEIVER STATUS

Menu	Description
Link's frequency	The frequency of apparatus is displayed
P.L.L. Status	Status: LOCK: P.L.L. Locked UNLOCK: P.L.L. Unlocked N/A: Communication with P.L.L. lost
RF field	The Receiver's RF field is displayed
Voltage Read-Out	The operating voltages of apparatus are displayed
RS-485 Status	A summary of address in use, communication and parity errors is displayed

1.5 RS-485

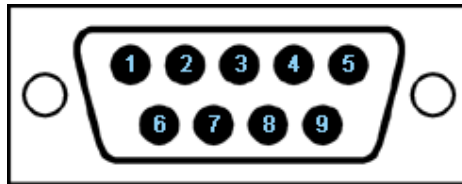

Figure 4: RS 485 9 pin connectors

PIN 1 A
PIN 2 B
PIN 9 GND

PIN 3-4-5-6-7-8 not used.

1.6 REM METER

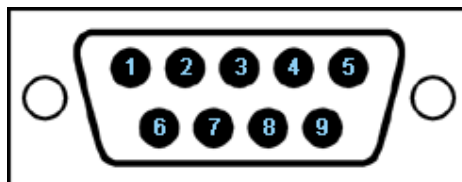
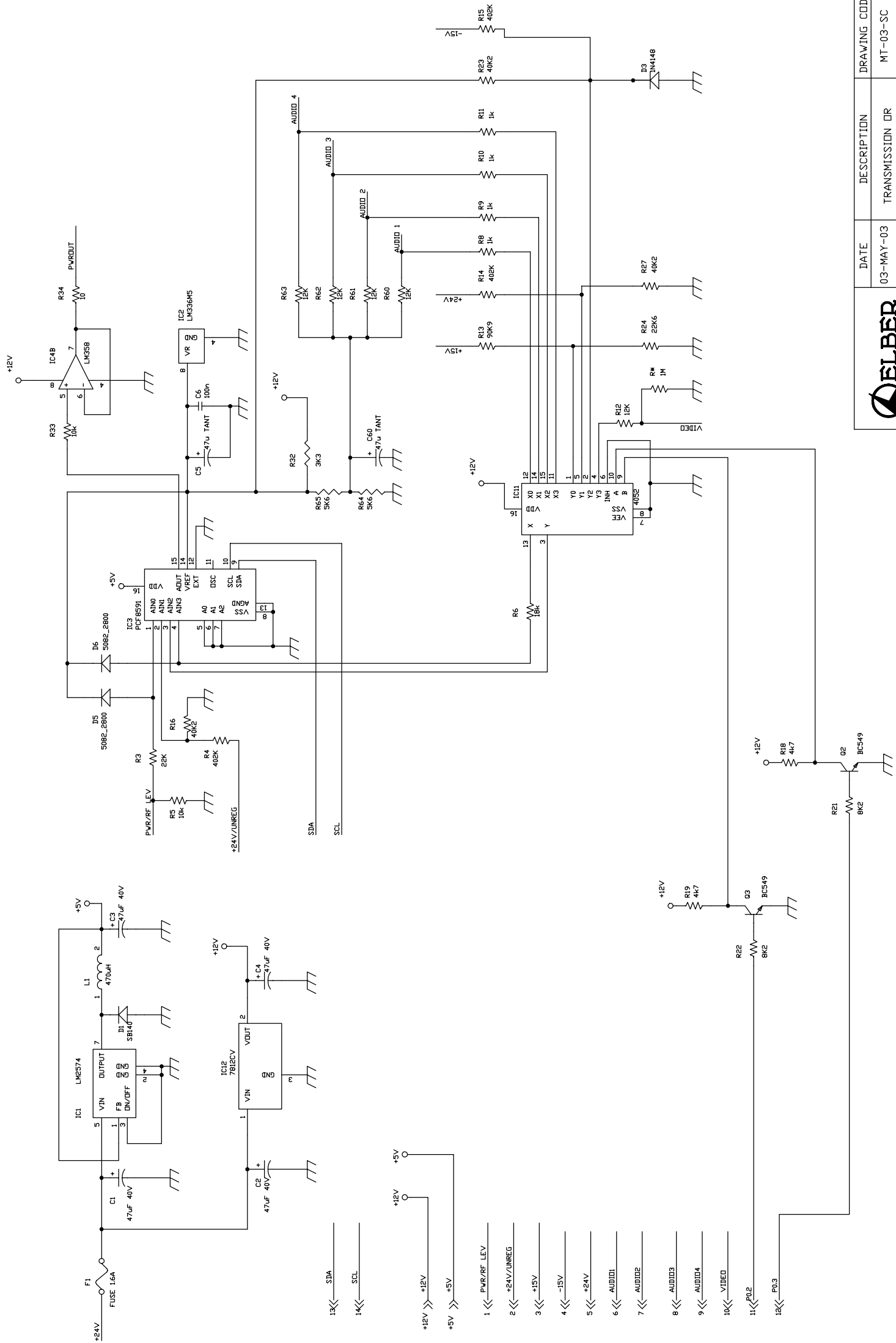



Figure 5: REM METER 9 pin connectors

PIN 1 : analogue voltage 0-5V that corresponds to the output RF power (Tx) or the received RF field (Rx)

PIN 3: indicates the presence of the video's pilot signal available in the analogue demodulators

PIN 5 : GND



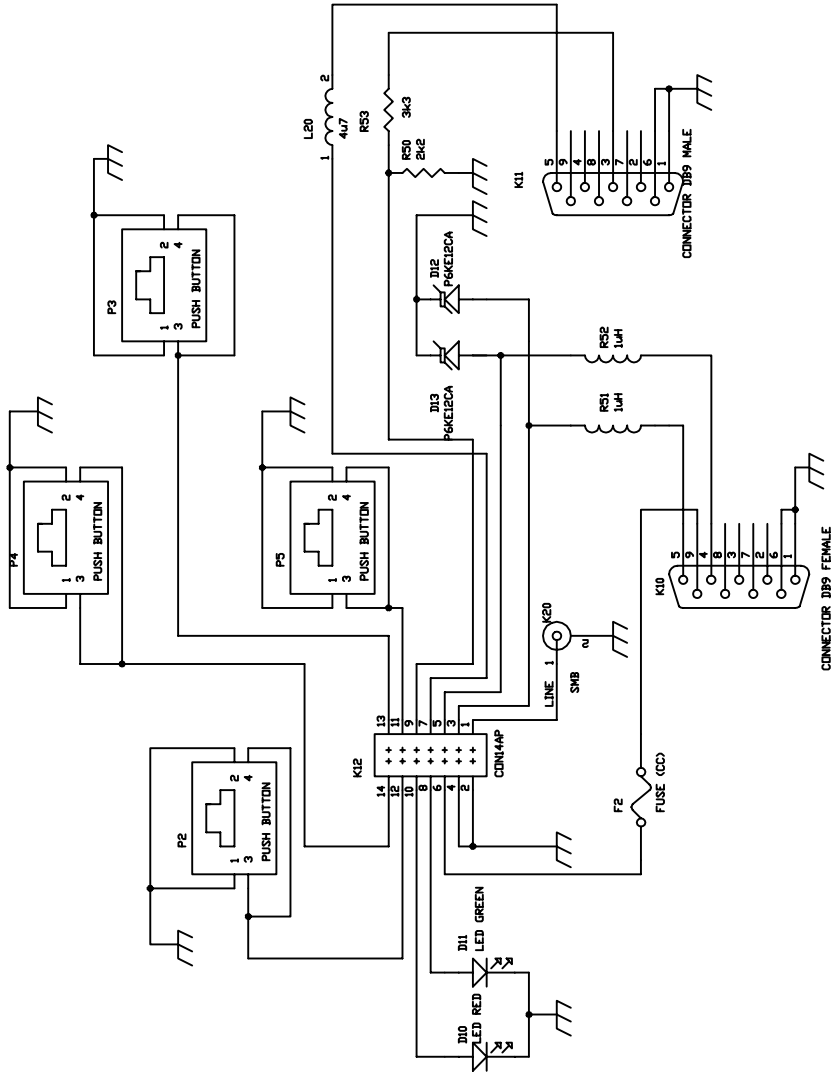

	DATE	DESCRIPTION	DRAWING CODE
	03-MAY-03	TRANSMISSION OR RECEPTION METER	MT-03-SC



DRAWING CODE	DESCRIPTION	DATE
MT-05-SC	TRANSMISSION OR RECEPTION METER	03-MAY-03

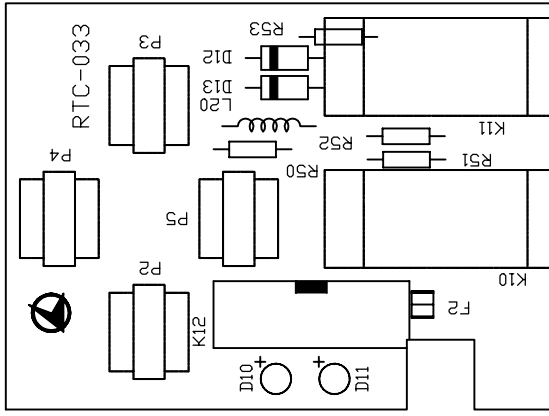
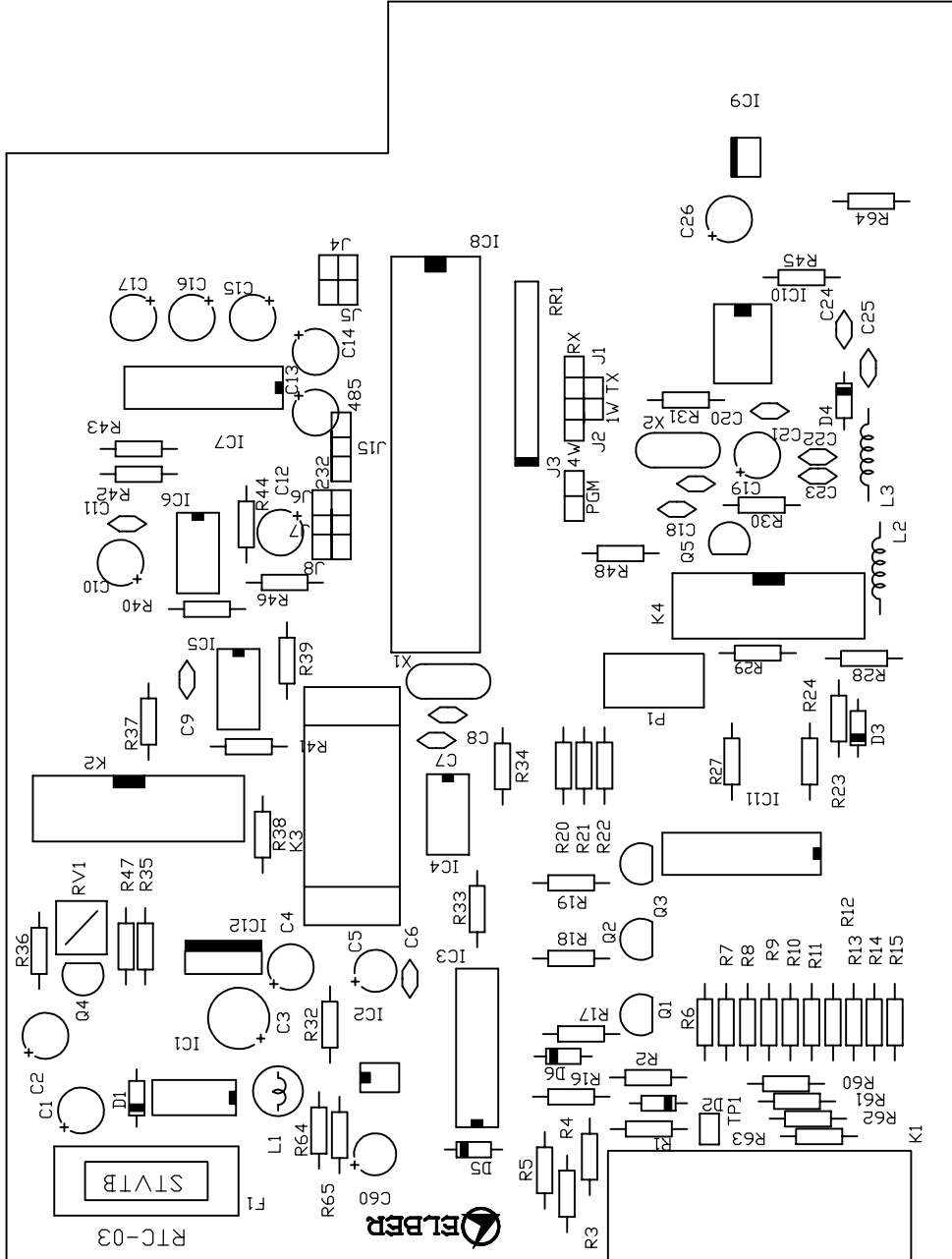



	DATE	DESCRIPTION	DRAWING CODE
	25-MAY-03	TRANSMISSION OR RECEPTION METER	MT-05-CL

RTC-03

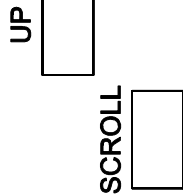

● ALARM

● ON



LINE

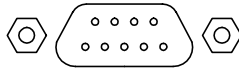

REM METER

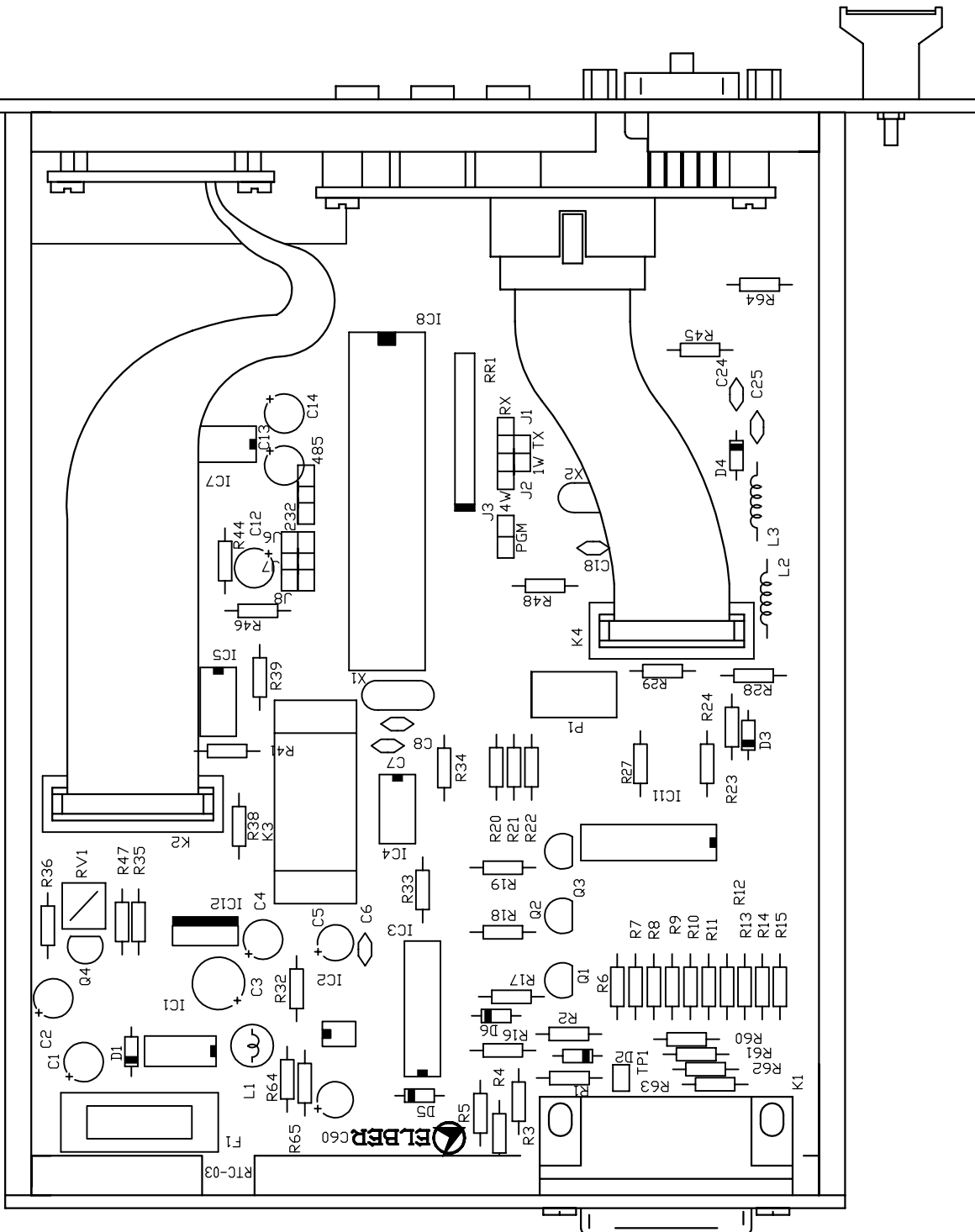

AUDIO MODULATOR 3 / 4

TECHNICAL SPECIFICATIONS

SUBCARRIER FREQUENCY AUDIO 3	7020 KHz
SUBCARRIER FREQUENCY AUDIO 4	8590 KHz
SUBCARRIER OUTPUT LEVEL	-14 dBm (50 mv eff) at 75 OHM
OUTPUT RETURN LOSS	< -20 dB
DEVIATION	70 KHz eff
PREEMPHASIS	50 usec (could be excluded by internal jumper)
AUDIO BANDWIDTH	15 KHz at 0.5dB
TOTAL HARMONIC DISTORSION	< 0.5%
S/N WEIGHTED (with pre/deemphasis)	> 64 dB with 70 KHz deviation > 70 dB with 140 KHz deviation
AUDIO INPUT LEVEL	setable with internal jumpers for: 0dBm,+3dBm,+6dBm, +9dBm
AUDIO INPUT IMPEDANCE	182 KOHM or 600 OHM (electronically balanced)
INPUT IMPEDANCE SELECTION	by internal jumpers

CIRCUIT DESCRIPTION

Audio 3 circuit

The balanced audio signal, present in the input connector AUDIO 3, is differentially amplified from IC5A. The input impedance value is preset by jumper J1. The second section of IC5 (IC5B) is connected to a low-pass filter with a cut off at 20KHz and a roll-off at 18 dB/octave.

The amplifier IC4 provides the preemphasis (excluded with J3) and allows the gain adjustment of Audio 3 signal through the position of jumper J4, according to the following values:

Position	Gain
1	0dbm
2	+3dbm
3	+6dbm
4	+9dbm

The Audio signal, applied to the varicap D1, D2, D3 (in parallel), modulates in frequency the VCO constituted by Q6 and associated elements. The modulation sensitivity is adjusted through RV4.

Through pin 6 of the BUS, the modulated audio signal is sent to the TRANSMITTER METER MODULE; then a selection is sent to the VIDEO COMBINER which detects it to drive the monitoring instrument of the frequency deviation present on the TRANSMITTER METER MODULE.

The working frequency of the subcarrier generator is given by L2, the associated capacities (C39, C41, C44, C46, C47, C48) and the total capacity of the varicap, which bias depends on the setting of RV3 and also on the resistance value of NTC C57, which has the function to stabilize the oscillation frequency versus the temperature variation.

The modulated signal of Audio 3 subcarrier is:

- amplified and filtered (through L1 and C50) by Q5,
- adjusted in level by RV1,
- sent (via the emitter follower Q4 and the resistance R8) to the connector SC OUT, where is mixed with the modulated signal of audio 4 subcarrier.

Audio 4 circuit

The balanced audio signal, present in the input connector AUDIO 4, is differentially amplified from IC3A. The input impedance value is preset by jumper J5. The second section of IC3 (IC3B) is connected to a low-pass filter with a cut off at 20KHz and a roll-off at 18 dB/octave.

The amplifier IC2 provides the preemphasis (excluded with J7) and allows the gain adjustment of Audio 4 signal through the position of jumper J8, according to the following values:

Position	Gain
1	0dbm
2	+3dbm
3	+6dbm
4	+9dbm

The Audio signal, applied to the varicap D5, D6 (in parallel), modulates in frequency the VCO constituted by Q2 and associated elements. The modulation sensitivity is adjusted through RV6.

Through pin 4 of the BUS, the modulated audio signal is sent to the TRANSMITTER METER MODULE; after a selection is sent to the VIDEO COMBINER which detects it to drive the monitoring instrument of the frequency deviation present on the TRANSMITTER METER MODULE.

The working frequency of the subcarrier generator is given by L4, the associated capacities (C4, C5, C6, C7, C9, C10) and the total capacity of the varicap, which bias depends on the setting of RV5 and also on the resistance value of NTC C58, which has the function to stabilize the oscillation frequency versus the temperature variation.

The modulated signal of Audio 4 subcarrier is:

- amplified and filtered (through L3 and C1) by Q1,
- adjusted in level by RV2,
- sent (via the emitter follower Q3 and the resistance R9) to the connector SC OUT, where is mixed with the modulated signal of audio 3 subcarrier.

SETUP and ADJUSTMENT PROCEDURE

INSTRUMENTS REQUIRED

- Frequency counter
- FM modulation meter
- RF millivoltmeter
- Audio Generator
- DC Voltmeter

SUBCARRIER 3

VARICAP DIODES BIAS ADJUSTMENT

Voltmeter DC

Connection

Jumpers

Adjustment

J12

J1: LL J3: ON J4: 9 J9: A3

RV3 for getting a level of 6,32 Volts.

VCO CENTRAL FREQUENCY ADJUSTMENT

Frequency Counter

Connection

Jumpers

Adjustment

output SC-OUT of the module.

J1: LL J3: ON J4: 9 J9: A3

Adjust L2 to get a reading of 7020 KHz
+/- 5KHz.

FILTER & LEVEL ADJUSTMENT

RF millivoltmeter

Frequency

Impedance

Connection

Jumpers

Adjustment

7020 KHz

75 OHM

output SC-OUT of the module

J1: LL J3: ON J4: 9 J9: A3

Adjust L1 for maximum output level

Adjust RV1 to get 70 mv eff at 75 OHM

MODULATION SENSITIVITY ADJUSTMENT

FM modulation meter

Central frequency

Connection

Audio generator

frequency

level

connector

Jumpers

Adjustment

7020 KHz

output SC-OUT of the module

1 KHz

+9 dBm.

input AUDIO 3 of the module

J1: LL J3: ON J4: 9 J9: A3

RV4 to get 70 KHz of r.m.s. deviation.

SUBCARRIER 4**VARICAP DIODES BIAS ADJUSTMENT****Voltmeter DC**

Connection

Jumpers

Adjustment

J11

J5: LL J7: ON J8: 9 J10: A4

RV5 for getting a level of 6,32 Volts.

VCO CENTRAL FREQUENCY ADJUSTMENT**Frequency Counter**

Connection

Jumpers

Adjustment

output SC-OUT of the module.

J5: LL J7: ON J8: 9 J10: A4

Adjust L4 to get a reading of 8590 KHz
+/- 5KHz.**FILTER & LEVEL ADJUSTMENT****RF millivoltmeter**

Frequency

Impedance

Connection

Jumpers**Adjustment**

8590 KHz

75 OHM

output SC-OUT of the module

J5: LL J7: ON J8: 9 J10: A4

Adjust L3 for maximum output level

Adjust RV2 to get 46 mv eff at 75 OHM

MODULATION SENSITIVITY ADJUSTMENT**FM modulation meter**

Central frequency

Connection

Audio generator

frequency

level

connector

Jumpers

Adjustment

8590 KHz

output SC-OUT of the module

1 KHz

+9 dBm.

input AUDIO 4 of the module

J5: LL J7: ON J8: 9 J10: A4

RV6 to get 70 KHz of r.m.s. deviation.

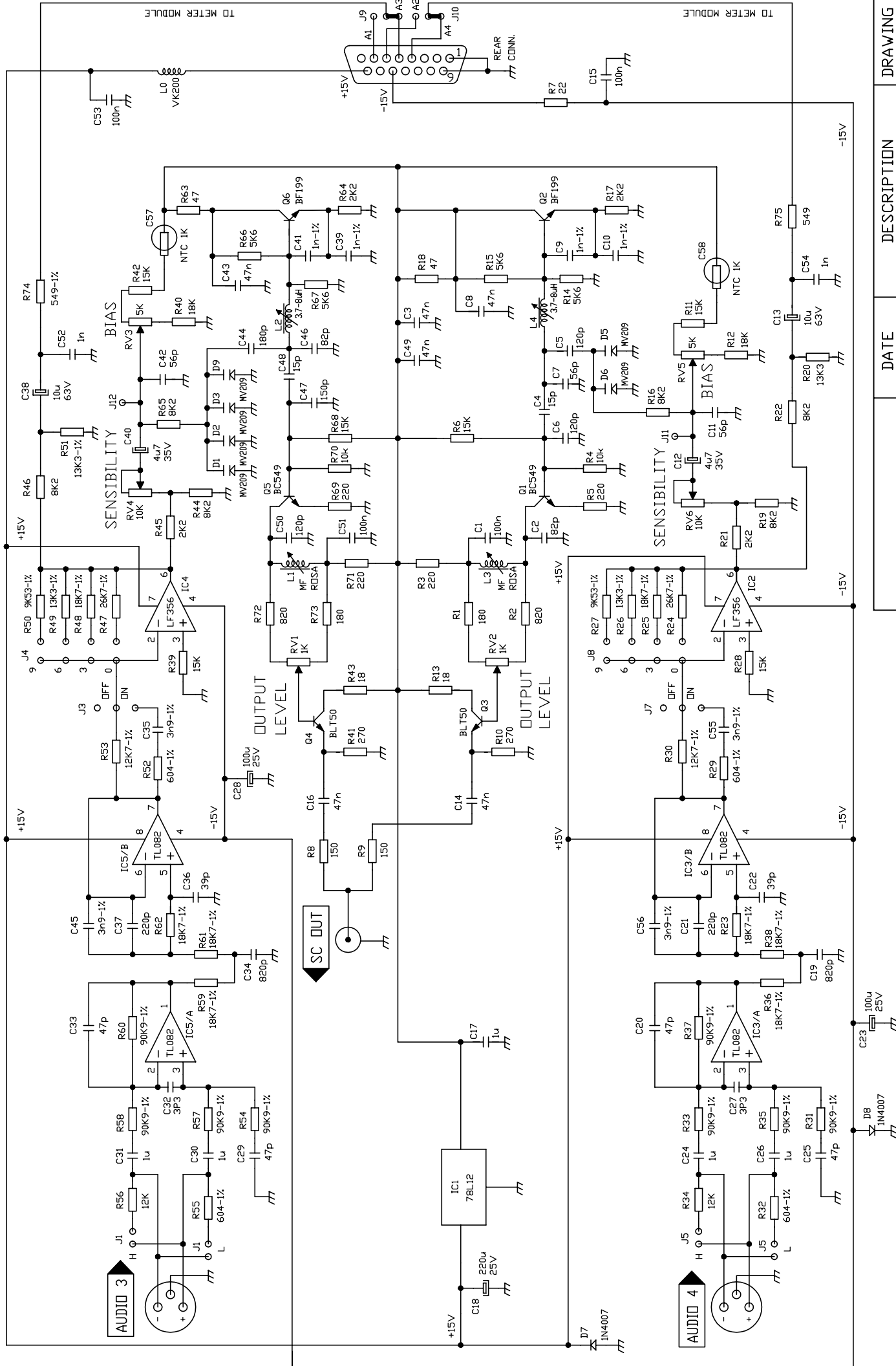

DATE	DESCRIPTION	DRAWING CODE
27-JUL-99	3-4 AUDIO MODULATOR	AM-07-SC

ALL RESISTORS IF NOT OTHERWISE INDICATED: 1/4W - 5%
 ALL CAPACITORS IF NOT OTHERWISE INDICATED: TOLERANCE 5%.

AUDIO MODULATOR 1 / 2

TECHNICAL SPECIFICATIONS

SUBCARRIER FREQUENCY AUDIO 1	7500 KHz
SUBCARRIER FREQUENCY AUDIO 2	8065 KHz
SUBCARRIER OUTPUT LEVEL	-14 dBm (50 mv eff) at 75 OHM
OUTPUT RETURN LOSS	< -20 dB
DEVIATION	70 KHz eff
PREEMPHASIS	50 usec (could be excluded by internal jumper)
AUDIO BANDWIDTH	15 KHz at 0.5dB
TOTAL HARMONIC DISTORSION	< 0.5%
S/N WEIGHTED (with pre/deemphasis)	> 64 dB with 70 KHz deviation > 70 dB with 140 KHz deviation
AUDIO INPUT LEVEL	setable with internal jumpers for: 0dBm,+3dBm,+6dBm, +9dBm
AUDIO INPUT IMPEDANCE	182 KOHM or 600 OHM (electronically balanced)
INPUT IMPEDANCE SELECTION	by internal jumpers

CIRCUIT DESCRIPTION

Audio 1 circuit

The balanced audio signal, present in the input connector AUDIO 1, is differentially amplified from IC5A. The input impedance value is preset by jumper J1 and J2. The second section of IC5 (IC5B) is connected to a low-pass filter with a cut off at 20KHz and a roll-off at 18 dB/octave.

The amplifier IC4 provides the preemphasis (excluded with J3) and allows the gain adjustment of Audio 1 signal through the position of jumper J4, according to the following values:

Position	Gain
1	0dbm
2	+3dbm
3	+6dbm
4	+9dbm

The Audio signal, applied to the varicap D1, D2, D3 (in parallel), modulates in frequency the VCO constituted by Q6 and associated elements. The modulation sensitivity is adjusted through RV4.

Through pin 7 of the BUS, the modulated audio signal is sent to the TRANSMITTER METER MODULE; then a selection is sent to the VIDEO COMBINER which detects it to drive the monitoring instrument of the frequency deviation present on the TRANSMITTER METER MODULE.

The working frequency of the subcarrier generator is given by L2, the associated capacities (C39, C41, C44, C46, C47, C48) and the total capacity of the varicap, which bias depends on the setting of RV3 and also on the resistance value of NTC C57, which has the function to stabilize the oscillation frequency versus the temperature variation.

The modulated signal of Audio 1 subcarrier is:

- amplified and filtered (through L1 and C50) by Q5,
- adjusted in level by RV1,
- sent (via the emitter follower Q4 and the resistance R8) to the connector SC OUT, where is mixed with the modulated signal of audio 2 subcarrier.

Audio 2 circuit

The balanced audio signal, present in the input connector AUDIO 2, is differentially amplified from IC3A. The input impedance value is preset by jumper J5. The second section of IC3 (IC3B) is connected to a low-pass filter with a cut off at 20KHz and a roll-off at 18 dB/octave.

The amplifier IC2 provides the preemphasis (excluded with J7) and allows the gain adjustment of Audio 2 signal through the position of jumper J8, according to the following values:

Position	Gain
1	0dbm
2	+3dbm
3	+6dbm
4	+9dbm

The Audio signal, applied to the varicap D4, D5, D6 (in parallel), modulates in frequency the VCO constituted by Q2 and associated elements. The modulation sensitivity is adjusted through RV6.

Through pin 6 of the BUS, the modulated audio signal is sent to the TRANSMITTER METER MODULE; after a selection is sent to the VIDEO COMBINER which detects it to drive the monitoring instrument of the frequency deviation present on the TRANSMITTER METER MODULE.

The working frequency of the subcarrier generator is given by L4, the associated capacities (C4, C5, C6, C7, C9, C10) and the total capacity of the varicap, which bias depends on the setting of RV5 and also on the resistance value of NTC C58, which has the function to stabilize the oscillation frequency versus the temperature variation.

The modulated signal of Audio 2 subcarrier is:

- amplified and filtered (through L3 and C1) by Q1,
- adjusted in level by RV2,
- sent (via the emitter follower Q3 and the resistance R9) to the connector SC OUT, where is mixed with the modulated signal of audio 1 subcarrier.

SETUP and ADJUSTMENT PROCEDURE

INSTRUMENTS REQUIRED

- Frequency counter
- FM modulation meter
- RF millivoltmeter
- Audio Generator
- DC Voltmeter

SUBCARRIER 1

VARICAP DIODES BIAS ADJUSTMENT

Voltmeter DC

Connection

Jumpers

Adjustment

J12

J1: LL J3: ON J4: 9 J9: A1

RV3 for getting a level of 6.32 Volts

VCO CENTRAL FREQUENCY ADJUSTMENT

Frequency counter

Connection

Jumpers

Adjustment

output SC OUT of the module

J1: LL J3: ON J4: 9 J9: A1

Adjust L2 to get a reading of 7500 KHz
+/- 5KHz.

FILTER & LEVEL ADJUSTMENT

RF millivoltmeter

Frequency

Impedance

Connection

Jumpers

Adjustment

7500 KHz

75 OHM

output SC OUT of the module

J1: LL J3: ON J4: 9 J9: A1

- Adjust L1 for a maximum output level
- Adjust RV1 to get 70 mv eff at 75 OHM
- In case of having 4 audio, adjust RV1 to get 46 mv eff at 75 OHM

MODULATION SENSITIVITY ADJUSTMENT

FM modulation meter

Central frequency

Connection

Audio generator

frequency

level

connector

Jumpers

Adjustment

7500 KHz

output SC-OUT of the module

1 KHz

+9 dBm.

input AUDIO 1 of the module

J1: LL J3: ON J4: 9 J9: A1

RV4 to get 70 KHz of r.m.s. deviation.

SUBCARRIER 2**VARICAP DIODES BIAS ADJUSTMENT****Voltmeter DC**

Connection

Jumpers

Adjustment

J11

J5: LL J7: ON J8: 9 J10: A2

RV5 for getting a level of 6.32 Volts

VCO CENTRAL FREQUENCY ADJUSTMENT**Frequency counter**

Connection

Jumpers

Adjustment

output SC OUT of the module.

J5: LL J7: ON J8: 9 J10: A2

Adjust L4 to get a reading of 8065 KHz

+/- 5KHz

FILTER & LEVEL ADJUSTMENT**RF millivoltmeter**

Frequency

Impedance

Connection

Jumpers**Adjustment**

8065 KHz

75 OHM

output SC OUT of the module

J5: LL J7: ON J8: 9 J10: A2

- Adjust L3 for a maximum output level
- Adjust RV2 to get 70 mv eff at 75 OHM
- In case of having 4 audio, adjust RV2 to get 46 mv eff at 75 OHM

MODULATION SENSITIVITY ADJUSTMENT**FM modulation meter**

Central frequency

Connection

Audio generator

frequency

level

connector

Jumpers

Adjustment

8065 KHz

output SC OUT of the module

1 KHz

+9 dBm.

input AUDIO 2 of the module

J5: LL J7: ON J8: 9 J10: A2

RV6 to get 70 KHz of r.m.s. deviation.

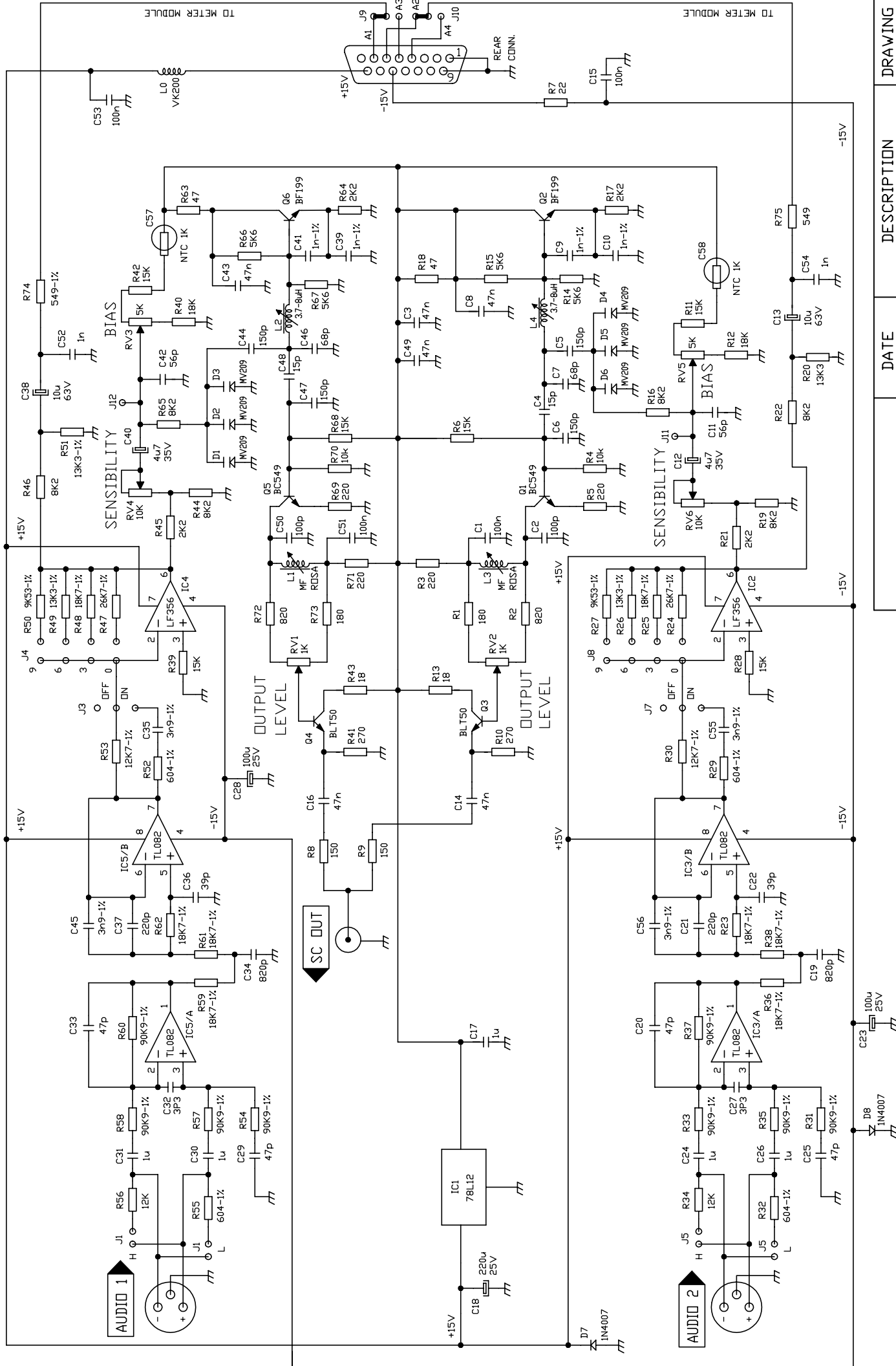

ALL RESISTORS IF NOT OTHERWISE INDICATED: 1/4W - 5%
 ALL CAPACITORS IF NOT OTHERWISE INDICATED: TOLERANCE 5%.

DATE	DESCRIPTION	DRAWING CODE
27-JUL-99	1-2 AUDIO MODULATOR	AM-06-SC

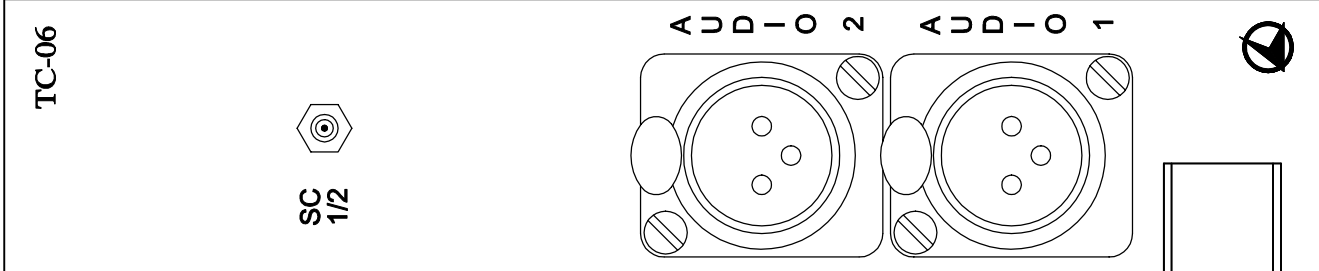
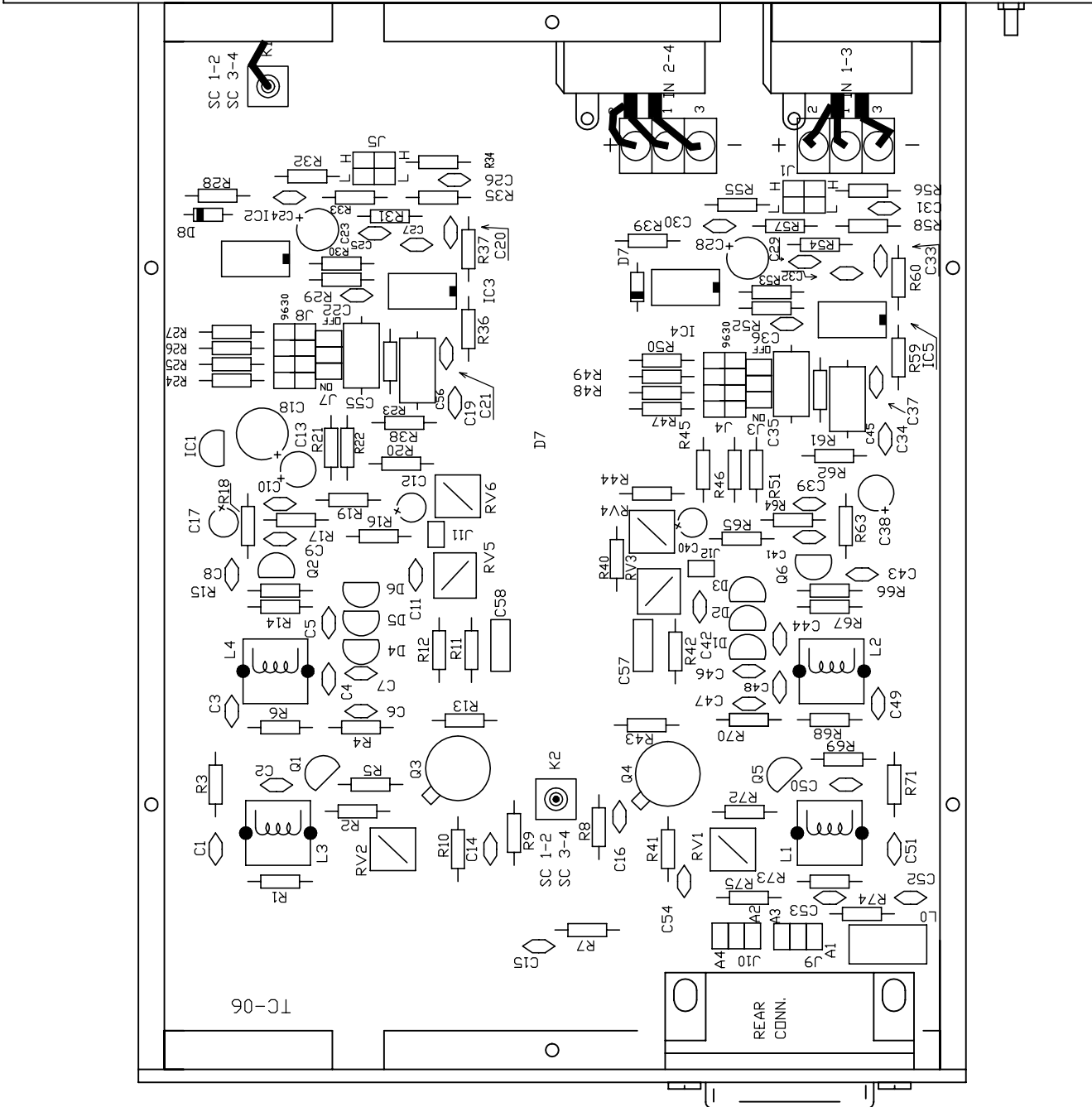

SC 1/2

	DATE	DESCRIPTION	DRAWING CODE
	28-JUL-99	AUDIO 1-2 MODULATOR	AM-10-CL

VIDEO COMBINER and AUDIO SUBCARRIERS

TECHNICAL SPECIFICATIONS

VIDEO CHANNEL

INPUT LEVEL	1 V pp
INPUT IMPEDANCE	75 OHM
INPUT RETURN LOSS	> 28 dB
GAIN (CAL position)	0 dB
GAIN (VAR position)	from +6 dB to -6 dB
BANDWIDTH	
with Video filter inserted	5.8 MHz @ +/- 0.25 dB
with Video filter excluded	10 MHz @ +/- 0.5 dB
OUTPUT RETURN LOSS	> 28 dB
ISOLATION BETWEEN OUTPUTS	> 28 dB

SUBCARRIERS

FREQUENCY BAND	6.8 MHz - 9.5 MHz
NOMINAL INPUT LEVEL	-14 dBm (70 mv eff) at 75 OHM
INPUT RETURN LOSS	< -25 dB
GAIN	0 dB +/- 0.5 dB
OUTPUT RETURN LOSS	< -25 dB
ISOLATION BETWEEN OUTPUTS	> 25 dB

CIRCUIT DESCRIPTION

The video signal arrives to the amplifier-mixer stage (Q5, Q4, Q7) via filter FL1. This filter has a bandwidth of 6 MHz and is equalized in amplitude and group delay. If is required, FL1 could be excluded by switching J1 and J2.

The module video gain is equal to 1 (adjusted by RV3 internal trimmer) when the CAL/VAR switch on the panel is on CAL position. When this switch is on VAR position is possible to vary the video gain from +/- 6 dB by acting on the RV4 trimmer accessible from the panel.

The audio subcarrier pairs present on the SC IN input are mixed at the base of Q6 with the Video signal in the emitter of Q5. The module gain related to SC IN input is adjusted by RV2. The Pilot continuity subcarrier, wich frequency is equal to 9023 KHz, is mixed with this subcarriers. The pilot subcarrier is generated by Q1; the frequency is controlled by crystal X1 and the level could be adjusted by RV1; the SW1 switch, accessible from the frontal module allows the exclusion of the Pilot carrier.

The Video combiner module also supplies some monitoring functions:

- IC2 is a further detector that returns to the meter module-transmitter (by pin 8 of the REAR CONN.),
- or the peak value of the video signal coming out from the module BB OUT (taken and amplified by the video amplifier equipped by Q2 & Q3 and detected by D1)
- or else the peak value of the audio channel signal (coming from the multimeter module through pin 2 of the REAR CONN.).

The selection is made by the analogic switch IC3 according to the logic level present at pin 3 (and coming from the meter module – transmitter) of the REAR CONN (supply BUS).

If the Video combiner module is inserted in the MOD70 – *Slim Line* - set J3 in S position. This sends the IC2 output to IC4 via a green led (set on the front of the MOD70) wich indicates the presence of the video signal.

SETUP and ADJUSTMENT PROCEDURE

INSTRUMENTS REQUIRED

- RF generator (*)
 - Video generator (*)
 - Video analyzer or oscilloscope (*)
 - RF detector (*)
 - DC Voltmeter – DVM (*)
 - Frequency counter
- (*) input impedance/output = 75 OHM

VIDEO GAIN ADJUSTMENT AND VIDEO LEVEL DETECTOR

Video generator

Level 1V pp
 Connection VIDEO IN input of the module

Video analyzer or Oscilloscope

Connection BB MON output of the module
 Switch Video Lev SW2 CAL
 Switch Pilot SW1 OFF
 Adjustment RV3 to have a BB output a level = 1 Vpp

AUDIO SUBCARRIER ADJUSTMENT

RF Generator

Level -14 dBm
 Connection SC IN input of the module

RF Detector

Connection BB MON output of the module
 Video Switch Lev SW2 CAL
 Pilot Switch SW1 OFF
 Adjustment RV2 to have -14 dBm output

PILOT CARRIER FREQUENCY TUNING

Frequency counter

Impedance >1 MOHM (with C < 10 pf)
 Connection TP1
 Switch pilot SW1 ON
 Switch video level SW2 CAL
 Adjustment Adjust CV1 to get a reading of 9023 KHz +/- 5KHz

PILOT CARRIER LEVEL TUNING

RF detector

Connection BB OUT output of the module
 Switch Pilot SW1 ON
 Switch Video Lev SW2 CAL
 Adjustment L1 for maximum output
 RV1 for having -30 dBm output.

B

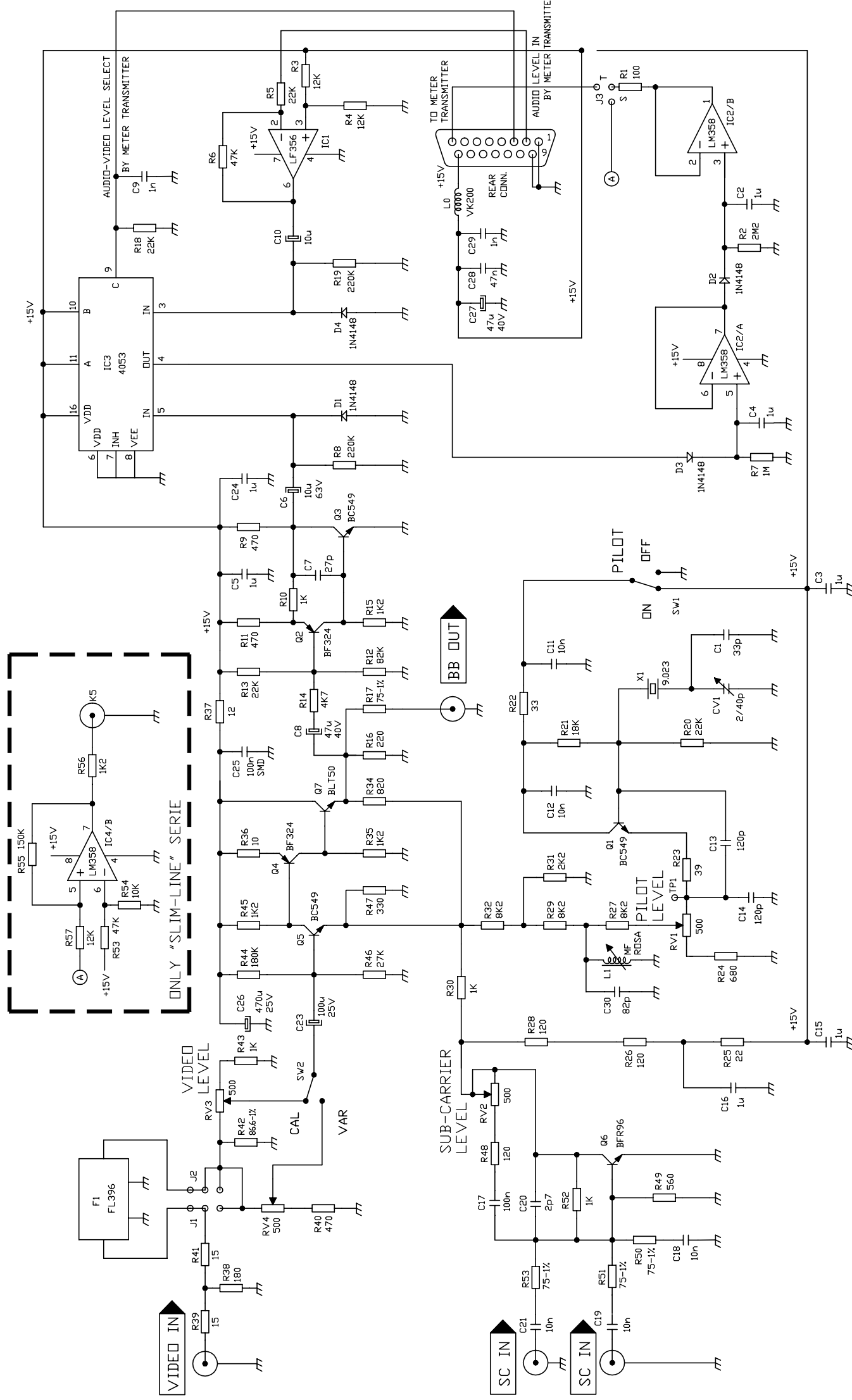

DATE	DESCRIPTION	DRAWING CODE
31-OCT-98	VIDEO COMBINER	VC-02-SC

ALL RESISTORS IF NOT OTHERWISE INDICATED: 1/4W - 5%
 ALL CAPACITORS IF NOT OTHERWISE INDICATED: TOLERANCE 5%.

TC-07

SC IN

SC IN

PILOT
on off

BB OUT

VIDEO LEVEL
cal var

J

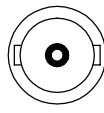

VIDEO IN

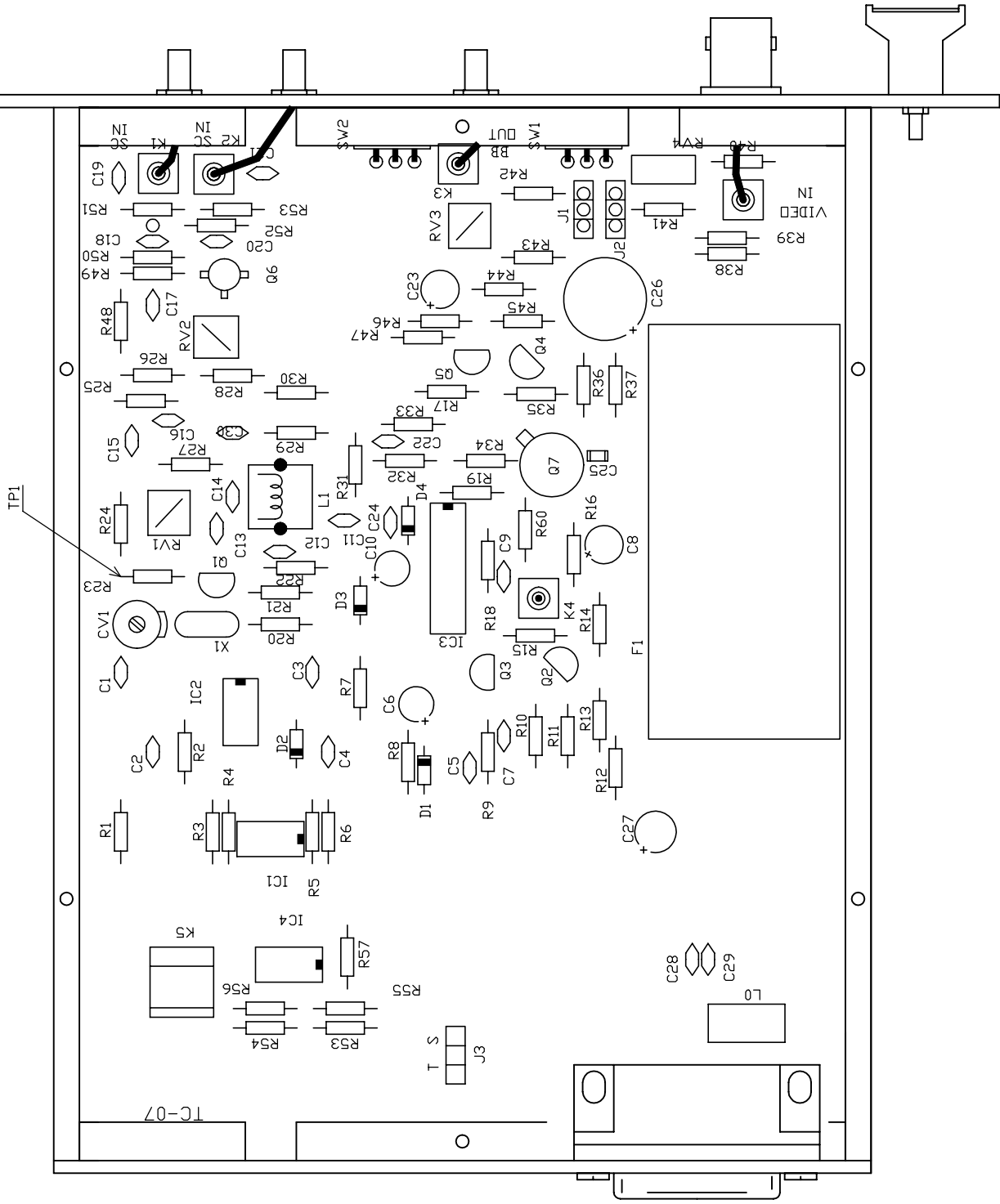

DATE	DESCRIPTION	DRAWING CODE
30-DEC-98	VIDEO COMBINER	VC-04-CL



IF - VIDEO MODULATOR

TECHNICAL SPECIFICATIONS

OUTPUT SPECIFICATIONS

CARRIER FREQUENCY	70 MHz +/- 10KHz
OUTPUT LEVEL	+ 5dBm
OUTPUT IMPEDANCE	75 OHM
OUTPUT RETURN LOSS	> 28 dB

BASE BAND INPUT SPECIFICATIONS

INPUT LEVEL (for $\Delta f = 8\text{MHz pp}$ at 1512 KHz)	1 V pp
INPUT IMPEDANCE	75 OHM
BANDWIDTH (ripple < 1 dB pp)	40 Hz / 10MHz
INPUT RETURN LOSS	> 28 dB
STATIC NONLINEARITY (+/- 8MHz)	< 1 %
GROUP DELAY	1 nsec
EMPHASIS	CCIR 405 - 1
DIFFERENTIAL GAIN	< 1%
DIFFERENTIAL PHASE	< 1°

CIRCUIT DESCRIPTION

The base band signal present at the BB IN input connector is amplified by a video amplifier equipped with Q4 and Q5 after having: a fixed attenuation of 3 dB, a preemphasis process and a variable attenuation (by RV2) inserted for the modulation sensitivity adjustment.

It is possible to substitute the preemphasis network with a fixed attenuator of 4dB by moving jumpers J1 and J2.

The VCO at 70 MHz is constituted by an astable oscillator that uses the transistors Q2, Q3, Q7 and Q8.

The circuit frequency centre, the sensitivity and the modulation linearity depend on the values of the resistive trimmers RV1 and RV3 and of the capacitive trimmer CV1.

The signal taken on collector of transistor Q2 is filtered by a low pass filter (L4, C25, C26 and C31) and amplified by Q6.

The module circuit frequency is controlled by a PLL circuit.

A part of the signal present on the collector of Q6 drives the prescaler IC5 (divider by 41).

To the phase detector (IC8) arrives the output signal to the divider chain that follow IC5 (IC6, IC7).

The total dividing ratio is equal to $41 * 2^5 * 2^{12}$.

The reference of the phase detector is obtained by dividing (IC10, IC9) the crystal oscillator frequency operating at 1707.3 KHz. The DC output of the phase detector, filtered and amplified by IC3, is sent in feedback to the emitter of Q8.

The PLL loop unlock is detected by IC8 that drives, through a level comparator/integrator equipped with IC8, the LED signalling, the PLL UNLOCK and the squelch circuits on the signal at 70 MHz. This last function consists in suppressing the module output in case of fault of PLL and is executed by commutating the PIN diodes (D3, D4) switch inserted between Q6 and the final amplifier (Q1).

SETUP and ADJUSTMENT PROCEDURE

INSTRUMENT REQUIRED

- Microwave link analyzer- generator
- Microwave link analyzer- receiver
- Voltmeter

VCO VOLTAGE SUPPLY ADJUSTMENT

Voltmeter

connection

output voltage regulator IC4

Adjustment

Regulate RV4 to obtain a reading = 21 Volts

WORKING POINT and VCO LINEARITY ADJUSTMENT

Generator

base band out:

signal -sweep:

-tone :

freq 70Hz

level 2Vpp

freq 250KHz

level 53 mVeff

BB IN input of the module

connection

Receiver

connection

IF OUT output of the module

Jumpers

J1:OFF J2:OFF (preemphasis off)

Adjustment

- deactivate the squelch by connecting pin 2 of IC1 (TP 3) to the voltage regulator output IC2 (9V)
- exclude the preemphasis by J1 and J2
- connect the voltmeter to pin 6 of IC3 (VCO voltage frequency control).
- Trimmer RV2 must be completely rotated clockwise (maximum modulation sensitivity).
- adjust repeatedly CV1, RV1 and RV3 to get
 - a correct lock of PLL at 70 MHz while the voltage control (indicated by the voltmeter) is equal to 6V.
 - a differential linearity distortion lower than 1%,
verifying that the frequency excursion remains at least equal to 16 MHz pp.
- reinsert the squelch, eliminating the connexion between pin 2 of IC1 and the output tension regulator IC2 9V.

VIDEO TILT ADJUSTMENT**Video generator**

connection

BB IN

Jumpers

J1:ON

J2:NO CONNECTED

Oscilloscope

connection

in J2 via a reference deemphasis close at 75 OHM

Adjustment

set L1 to get the required video TILT.

MODULATION SENSITIVITY ADJUSTMENT**Generator**

base band out

signal -sweep

freq 70 Hz

level 1Vpp

off

-tone

connection

Input BB IN of the module

Receiver

connection

Output IF OUT of the module

Jumpers

J1:OFF

J2:OFF

(preemphasis off)

Adjustment

RV2 for having a deviation equal to 8 MHz pp

Reinsert the preemphasis via J1 and J2.

TC-08

IF AUX

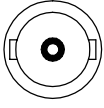

IF OUT



lock alarm

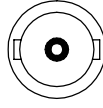

BB IN

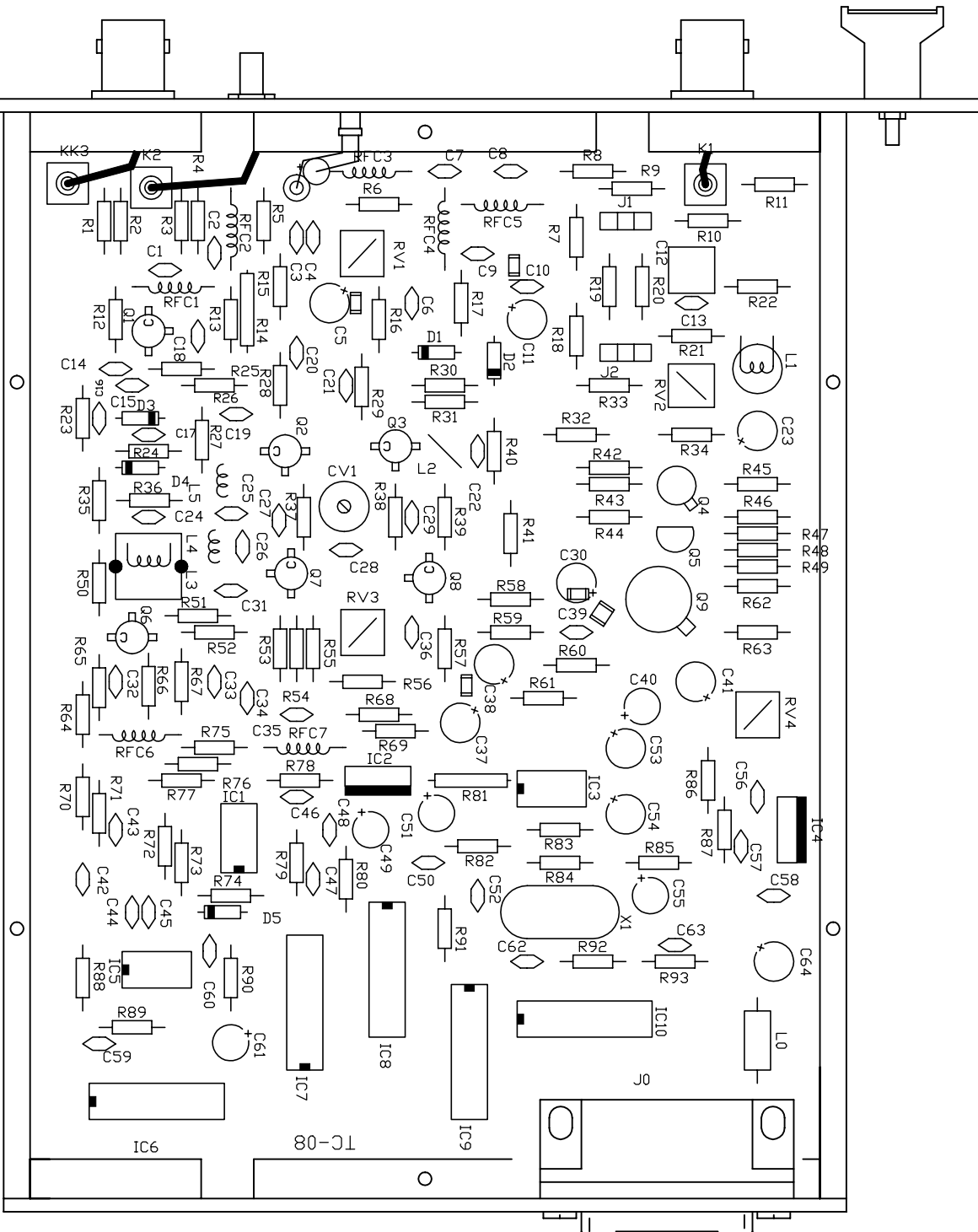

DRAWING CODE	IM-04-CL
	IF MODULATOR
DATE	30-DEC-98

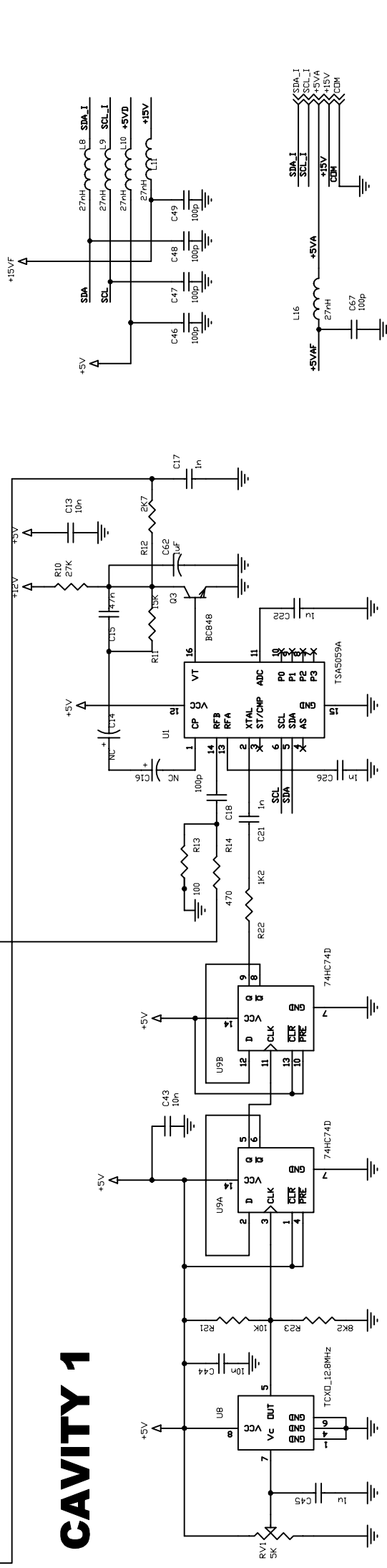
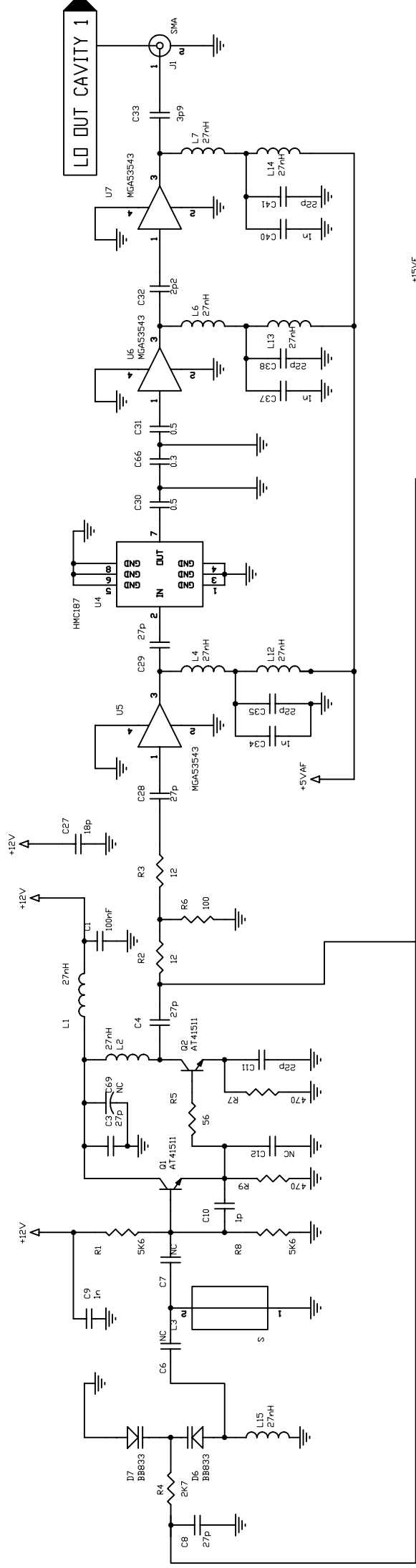

4.5-6.25 AND 9GHZ - 12Ghz	6.25-7.75 AND 12.5GHz - 15.5GHz
C6 1pF	C6 N.C.
C7 0.5pF	C7 0.3pF
C10 3.3pF	C10 N.C.

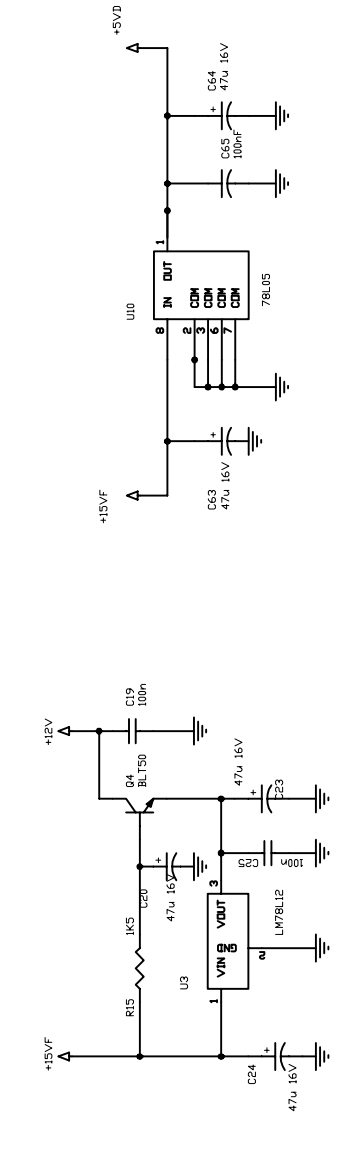

	DATE	DESCRIPTION	DRAWING CODE
	14-JAN-05	SYNTHESIZE OSCILLATOR	LD-23-SC

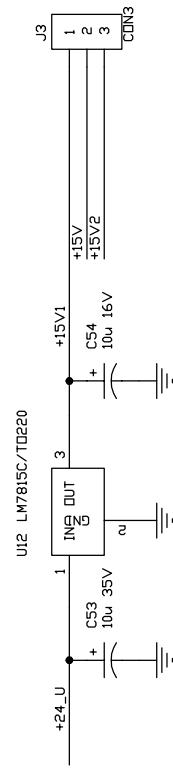
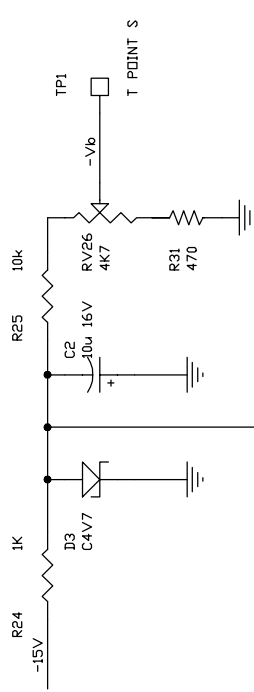
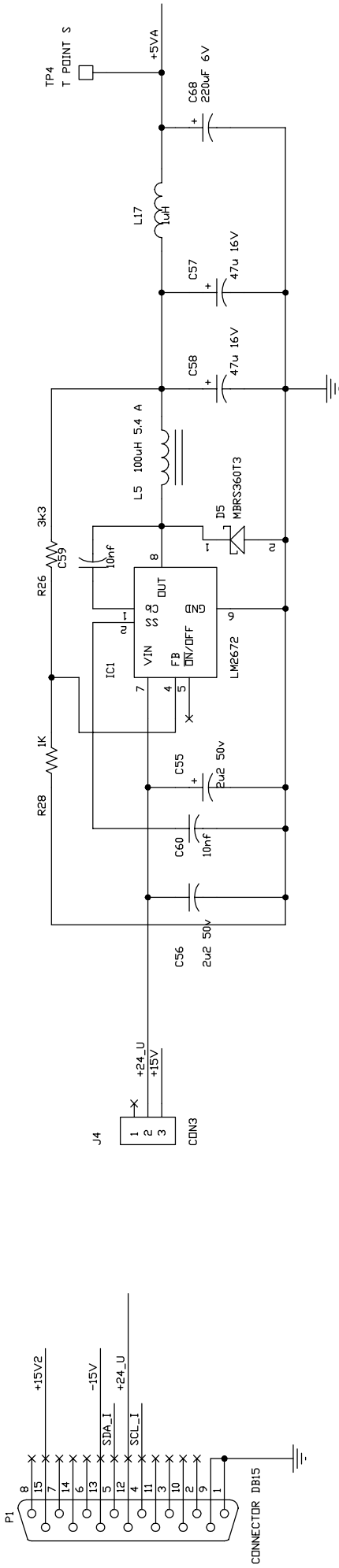

	DATE	DESCRIPTION	DRAWING CODE
	19-OCT-05	LOCAL OSCILLATOR	LO-31-SC

CAVITY 2 (ONLY FOR LO OUT=4.5-6.25GHZ)

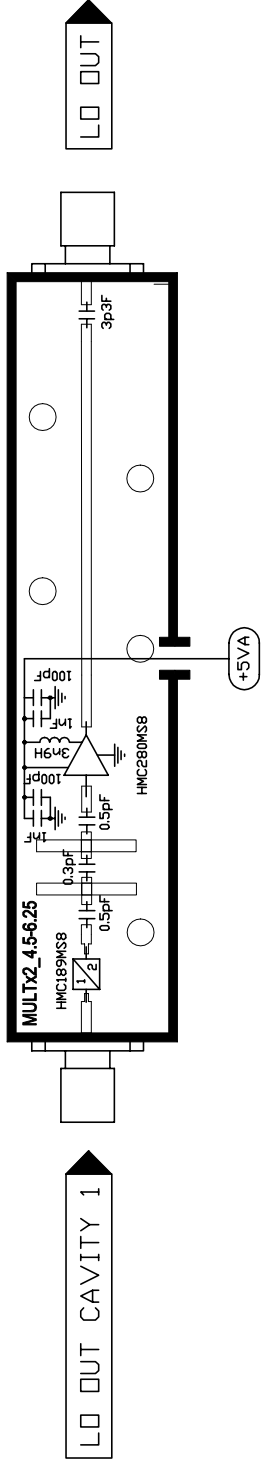

CAVITY 2 (ONLY FOR LO OUT=6.25-7.75GHZ)

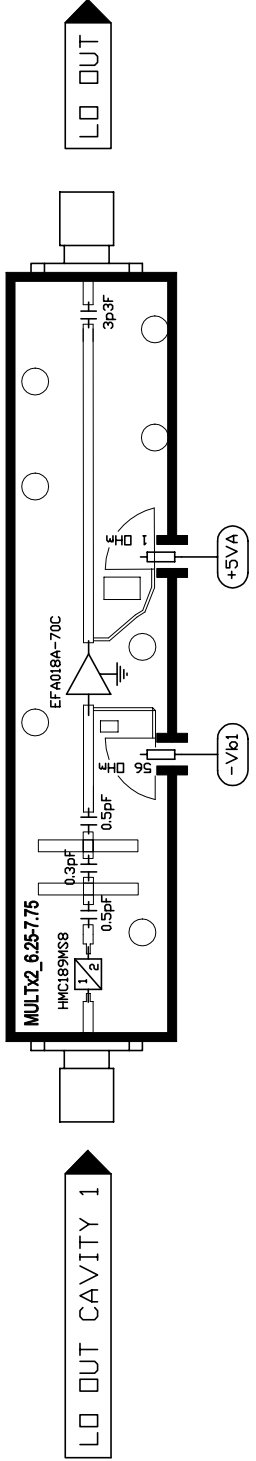

CAVITY 2 (ONLY FOR LO OUT=9-12.5GHZ)

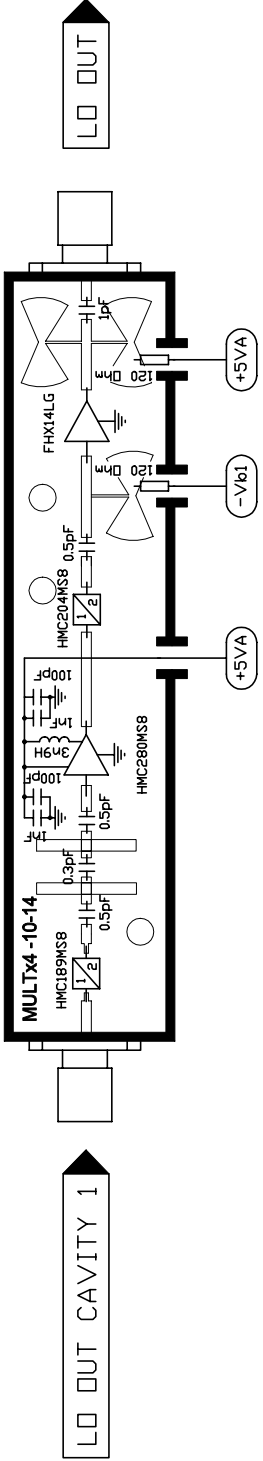

CAVITY 2 (ONLY FOR LO OUT=12.5-15.5GHZ)

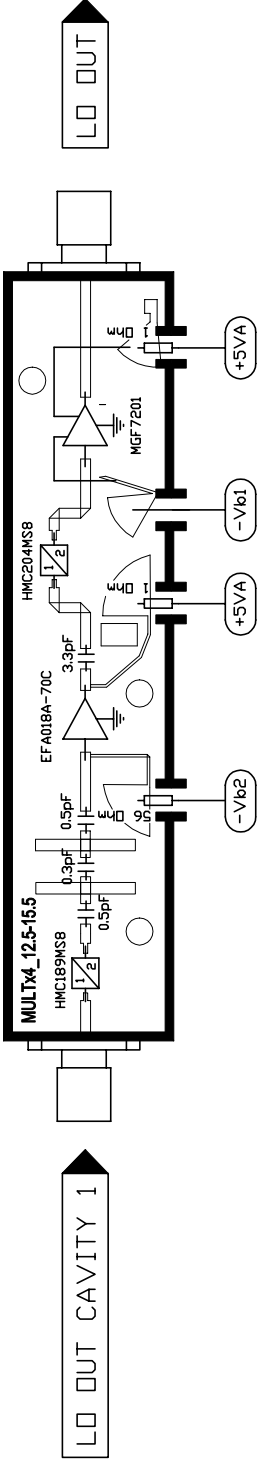

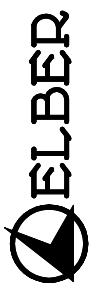
	DATE	DESCRIPTION	DRAWING CODE
	14-JAN-05	SYNTHESIZE OSCILLATOR	LD-22-SC

RTC-31

LO OUT

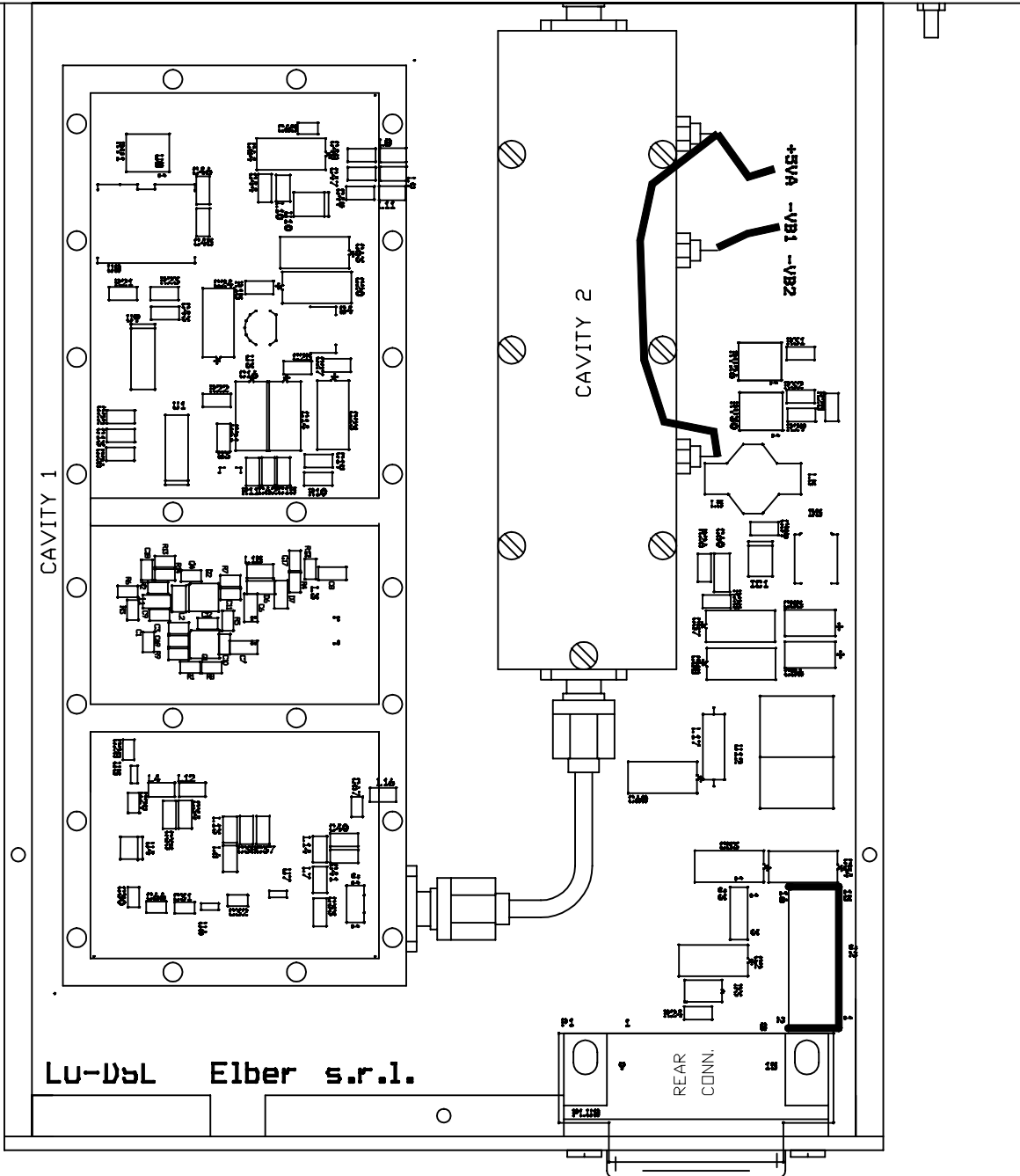

LU-D5L Elber s.r.l.

REAR CONN. PLATE

CAVITY 2

CAVITY 1

+SVA -VB1 -VB2
2BA

	DATE	DESCRIPTION	DRAWING CODE
	14-JAN-05	SYNTHESIZE OSCILLATOR 9-12.5 GHz	LD-25-CL

UP CONVERTER 10-15 GHz

TECHNICAL SPECIFICATIONS

FREQUENCY BAND	10200 / 10700 MHz 10700 / 11700 MHz 11700 / 12400 MHz 12400 / 12700 MHz 12700 / 13200 MHz 14200 / 14600 MHz 14600 / 15200 MHz
INPUT LEVEL	+ 5dBm
CONVERSION LOSS	< 5 dB
INPUT CONNECTOR	BNC Female
INPUT RETURN LOSS	>20 dB
OUTPUT CONNECTOR	SMA Female
OUTPUT RETURN LOSS	> 18 dB
GROUP DELAY	< 2 nsec (62 MHz - 78 MHz)
AMPLITUDE FREQUENCY FLATNESS	< 0.2 dB (Fout +/-15 MHz)

CIRCUIT DESCRIPTION

The frequency conversion happens in the UP CONVERTER module. This module contains a balanced mixer . The IF signal (Fif) is sent to the mixer module through an amplifier (Q1). The feedback of this amplifier guarantees the necessary isolation between the module IF input and the mixer IF input.

The Local Oscillator signal (Fol) is applied to the mixer from which are taken the conversion products (Fol + Fif e Fol - Fif) .

The correct impedance value with charge to the mixer and in input to the channel Filter are assured by the drop-in isolator assembled internally to the mixer.

The Local Oscillator residual signal, the image frequency and other conversion products in output to the mixer are attenuated by a microwave filter with five cells. This filter is executed in INVAR for not being influenced by the temperature variation.

A second isolator, installed between the filter output and the drawer RF output, keeps the VSWR in output to the filter low enough and independent from the module input adaptation that will be monitored.

SETUP and ADJUSTMENT PROCEDURE

INSTRUMENTATION REQUIRED

- Microwave network analyzer

FILTER ADJUSTMENT

Generator

central frequency

transmission channel central frequency

Δf

+/- 50 MHz

Connection

connector K1 of the filter

Analyzer

Connection

connector K2 of the filter

Adjustment

- Extract the filter of the module and connect it to the instrument as shown.
- Adjust the resonance frequency of 5 cells through the screws N°1, 3, 5, 7, 9 for a maximum reduction of the return loss in the band pass.
- Adjust the connection between the five cells through the screws N° 2, 4, 6, 8 to obtain the band pass. Every screw touching-up requires an adjustment retouch of the adjacent cavity resonance frequency.

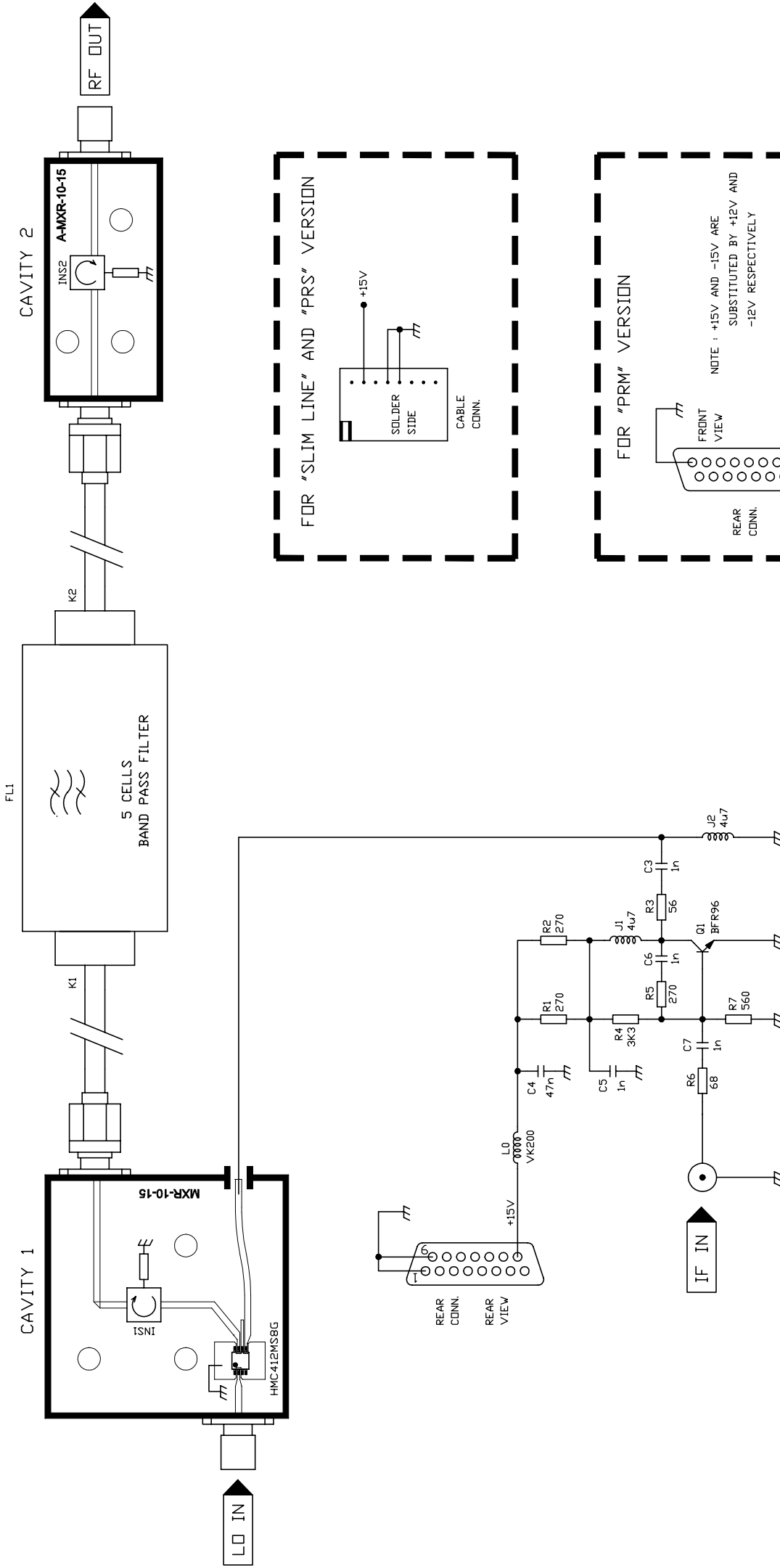



IMPORTANT

INS1=INS2=CKR11825M402 or similar between 10-13GHZ
 INS1=INS2=CKR13125M402 or similar between 13-15GHZ

ALL RESISTORS IF NOT OTHERWISE INDICATED: 1/4W - 5%
 ALL CAPACITORS IF NOT OTHERWISE INDICATED: TOLLERANCE 5%

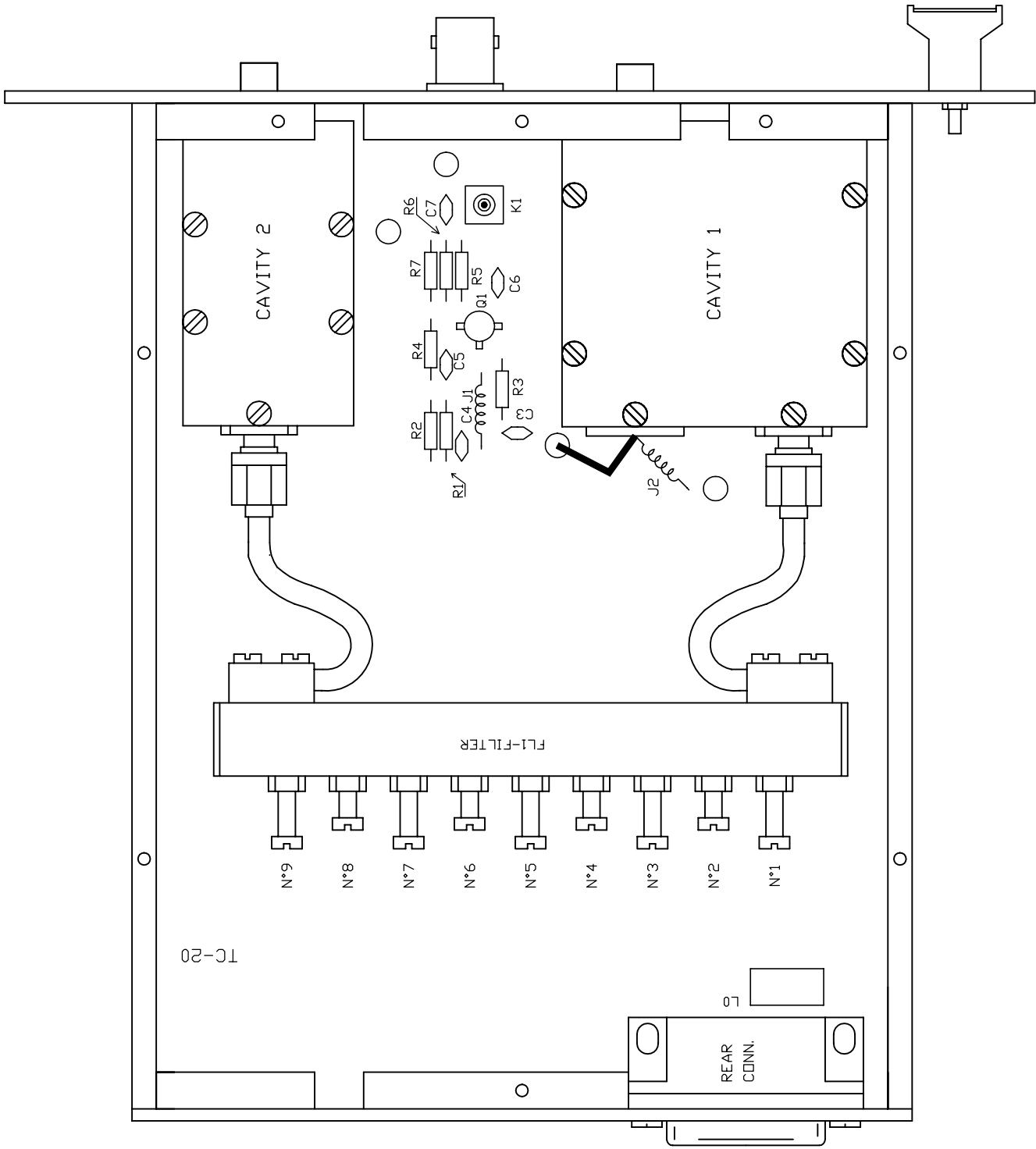
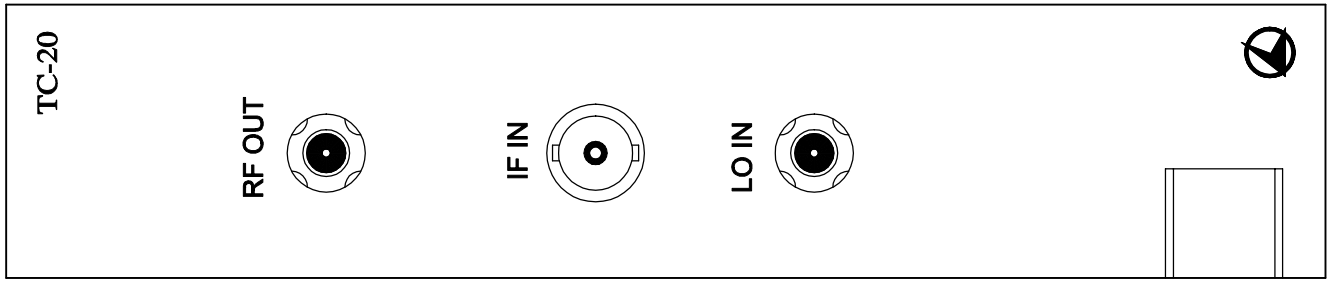
		DATE	DESCRIPTION	DRAWING CODE
		04-FEB-03	UP-CONVERTER 10-15 GHZ	UP-23-SC



	DATE	04-AUG-99
	DESCRIPTION	UP-CONVERTER 10-11GHZ
DRAWING CODE		UP-04-CL

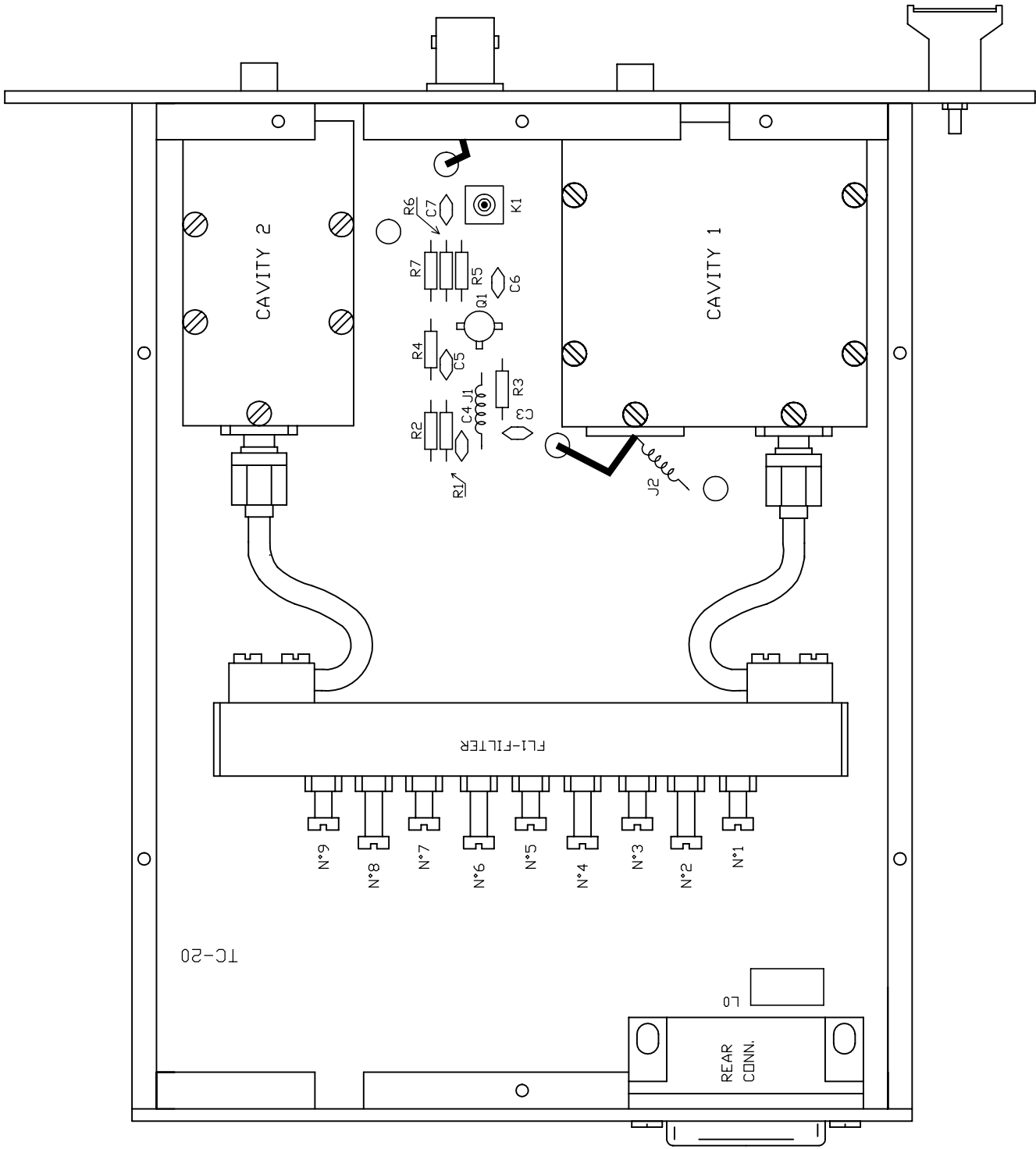
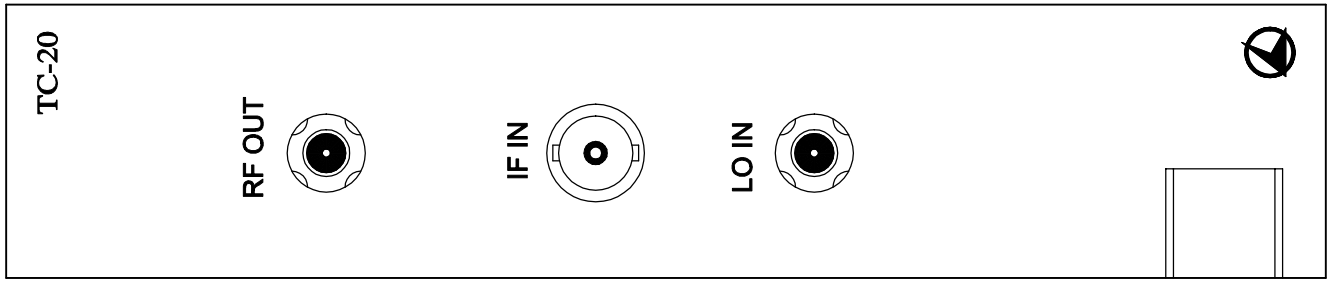

	DATE	04-AUG-99
	DESCRIPTION	UP-CONVERTER 11-12.4 GHz
DRAWING CODE		UP-07-CL

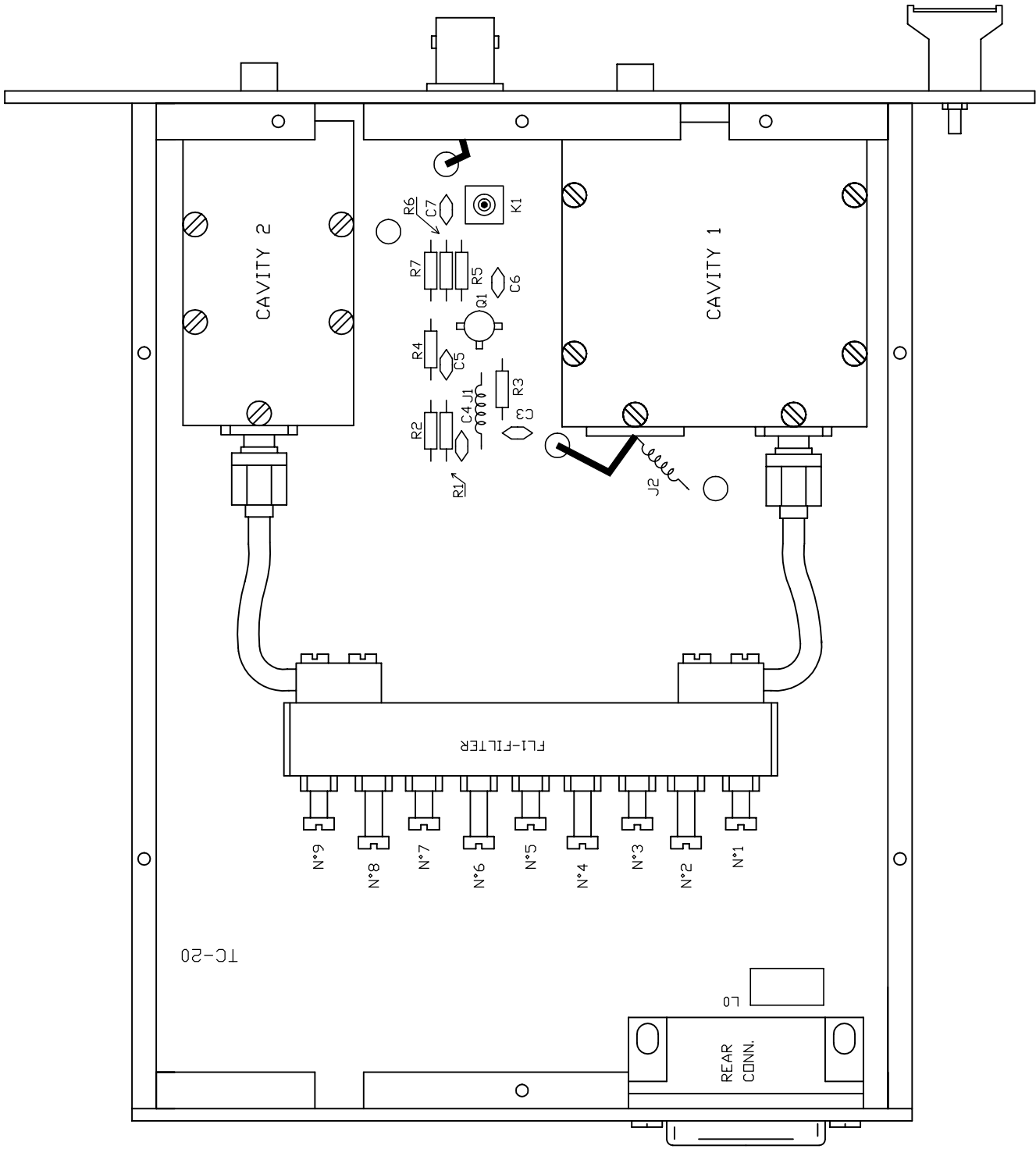
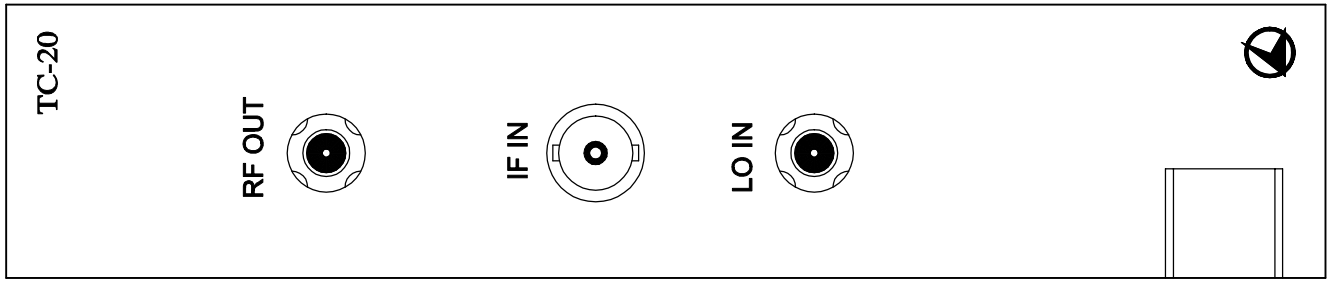

DATE	DESCRIPTION	DRAWING CODE
02-DEC-99	UP-CONVERTER 12.7-13.2 GHz	UP-10-CL



AMPLIFIER 10-11-12-13 GHz – 1W

TECHNICAL SPECIFICATIONS

FREQUENCY BAND	10200 / 10700 MHz 10700 / 11500 MHz 11700 / 12400 MHz 12700 / 13200 MHz
INPUT LEVEL	+ 0 dBm
OUTPUT LEVEL	+30 dBm +/- 1 dBm
SATURATED OUTPUT POWER	> 30 dBm
INPUT CONNECTOR	SMA Female
INPUT RETURN LOSS	>10 dB
OUTPUT CONNECTOR	SMA Female
OUTPUT RETURN LOSS	>18 dB

CIRCUIT DESCRIPTION

This amplifier unit supplies the power amplification of the signal coming out from the transmission mixer; it happens via a module equipped with a FET transistor (Q11) and with a integrated circuit MMIC (IC14). In output to this module there is inserted a RF detector. The signal for this detector is taken by a directional coupler integrated in the module. The continuous voltage level in output to the detector is amplified by IC2A and is sent to the link BUS via pin 10 of the REAR CONNECTOR.

The RF detector sensitivity adjustment could happen via RV3.

The positive supplies of the module are obtained directly from the voltage at 24V non stabilized via a switch of high efficiency (IC1).

The bias negative voltages are taken from the -15 volts present in the REAR CONNECTOR (pin 13) through a Zener diode stabilizer (D1).

The rotation of RV4 allows the correct value of the bias current required by Q11. This current can be read from the voltage drop, present across the reading resistance R21 (TP1/TP2).

For protecting the power RF transistors, the negative voltage is detected by IC2B, wich interrupts the output of the positive switching regulator in case of failure.

If the AMPLIFIER 10-11-12-13GHZ 1W pilots the AMPLIFIER 10-11-12-13GHZ 4W, disconnect R1 from the REAR CONNECTOR and connect this one to D8, located on the front panel of the module.

SETUP and ADJUSTMENT PROCEDURE

INSTRUMENTATION REQUIRED

- DC Voltmeter
- RF Generator
- Bolometer with attenuator

BIAS ADJUSTMENT

DC Voltmeter

connection

as prescribed in the adjustment section

Adjustment

Q11 bias

connect the voltmeter between TP1 and TP2
adjust RV4 for a reading equal to 1.3V
(I = 40mA approx.)

IC14 bias

connect the voltmeter between TP3 and TP4
check that reading is equal 155mV
(I = 1,4A approx.)

RF DETECTOR SENSITIVITY ADJUSTMENT

DC Voltmeter

connection

positive to pin 10 of the REAR CONNECTOR
negative to ground

RF Generatore

output level

frequency

see adjustment section
10500 MHz (10200 / 10700 MHz)
11100 MHz (10700 / 11500 MHz)
12000 MHz (11700 / 12400 MHz)
13000 MHz (12700 / 13200 MHz)

connection

RF IN connector of the module

Bolometer

sensitivity

connection

>2 Watt full scale
RF OUT output of the module

Adjustment

- adjust the generator output level for getting a bolometer reading (output power) equal to +30dBm
- Adjust RV3 in order to get a voltmeter reading equal to +4.5 V

CAVITY 1

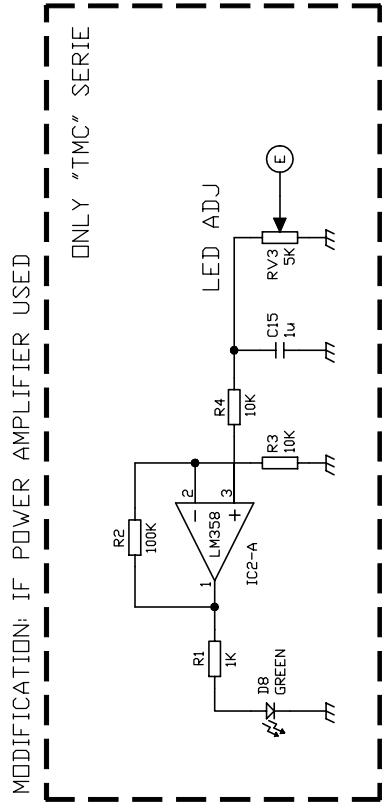
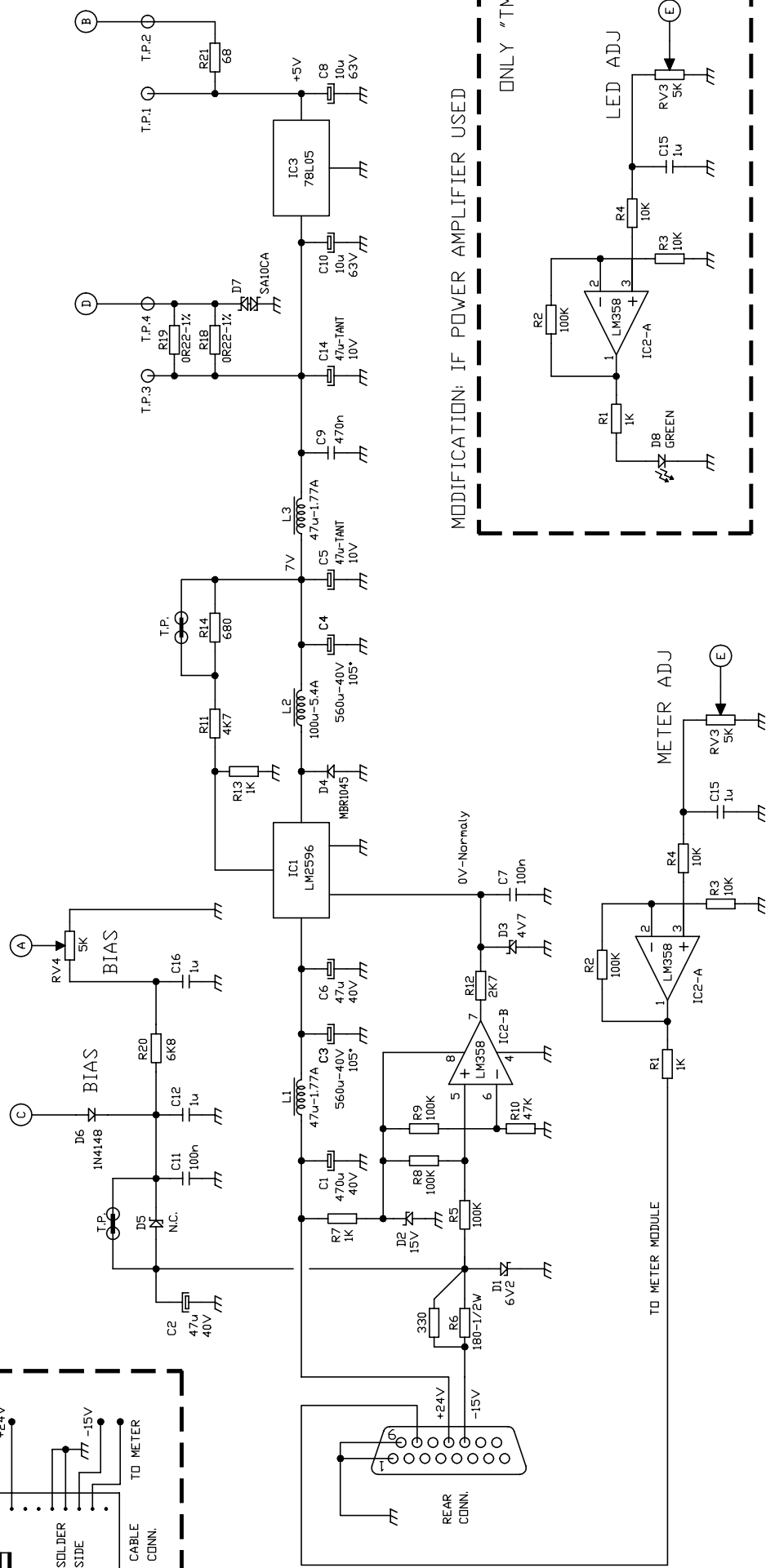
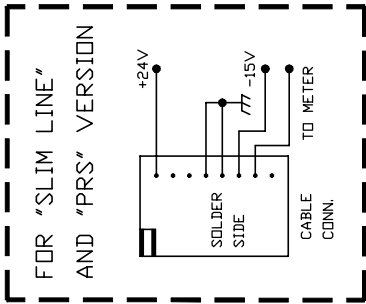
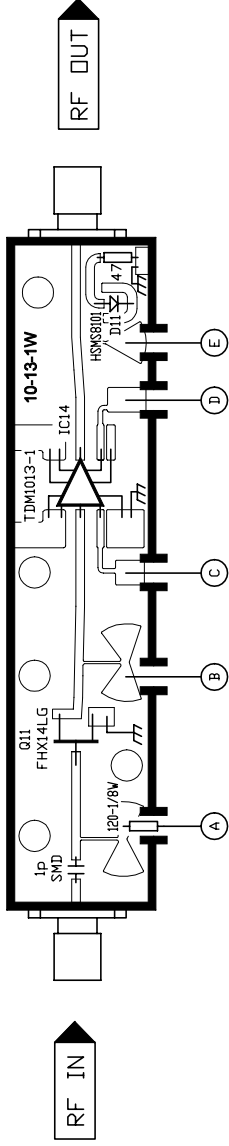

ALL RESISTORS IF NOT OTHERWISE INDICATED: 1/4W - 5%
 ALL CAPACITORS IF NOT OTHERWISE INDICATED: TOLERANCE 5%

	DATE	DESCRIPTION	DRAWING CODE
	02-DEC-99	AMPLIFIER 10-11-12-13 GHz 1W	AP-12-SC

TC-22

RF OUT



RF IN

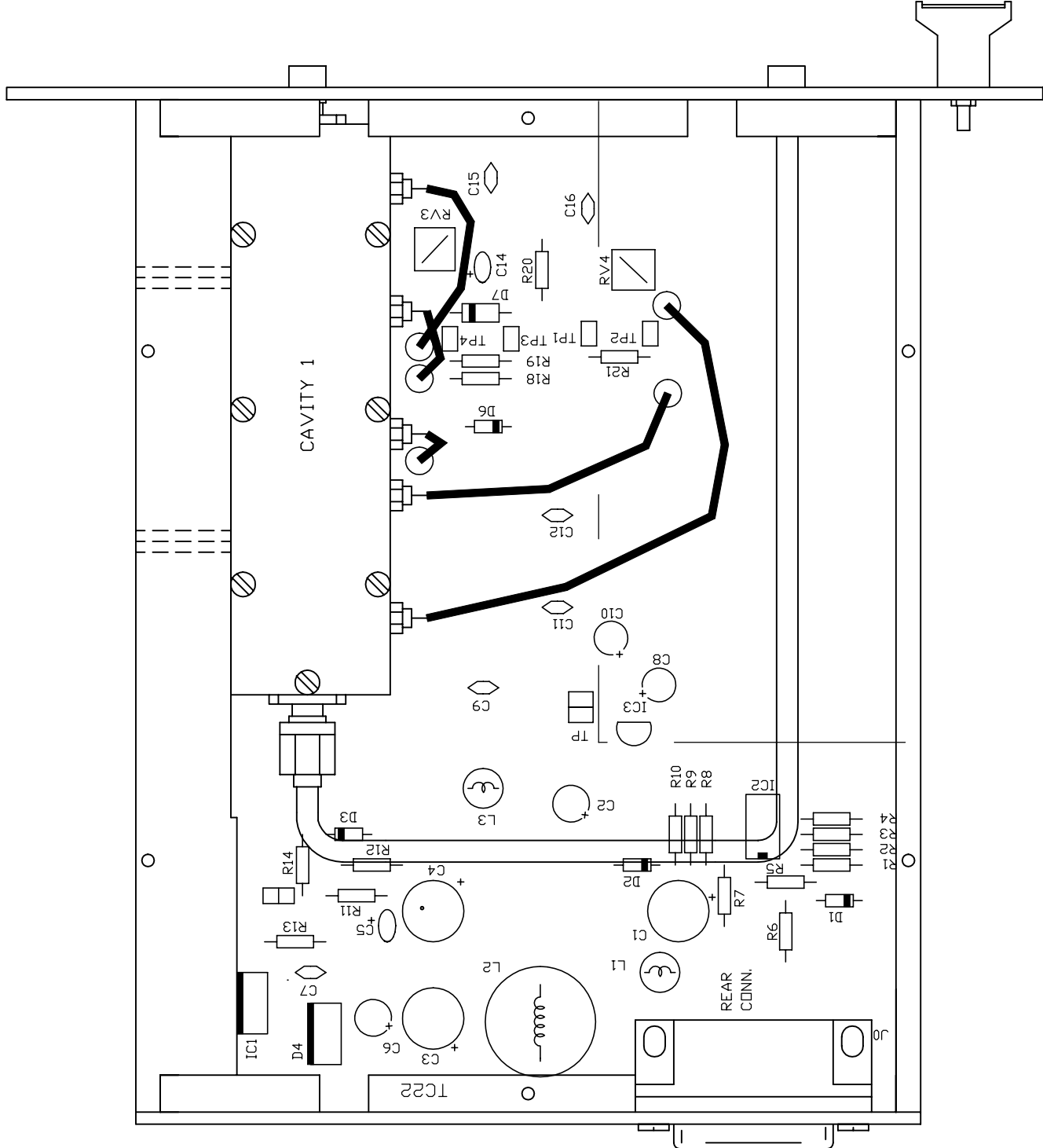

DATE	DESCRIPTION	DRAWING CODE
27-JAN-00	AMPLIFIER 10-11-12-13 GHz 1W	AP-12-CL



TC-22

RF OUT



RF IN

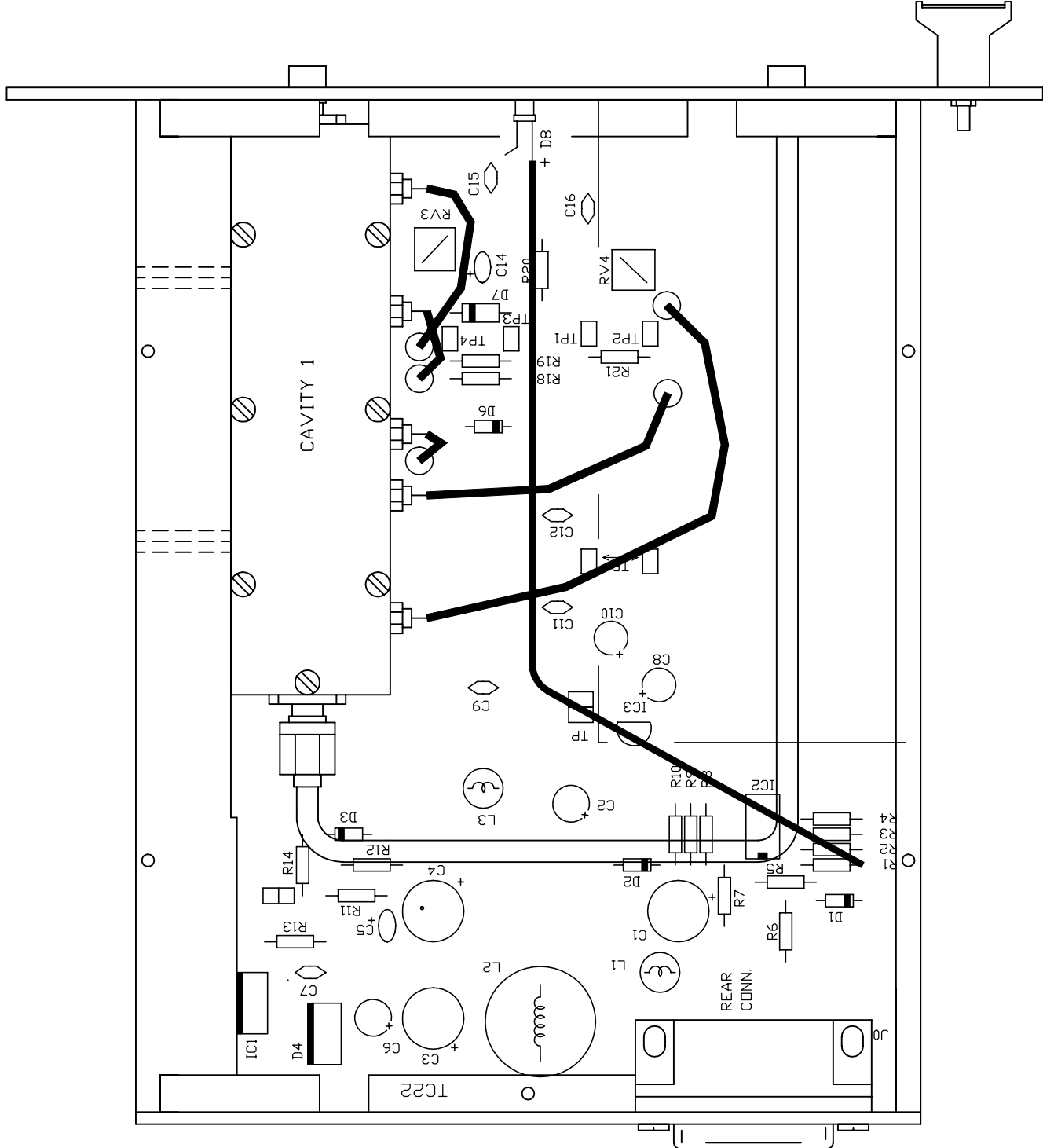

DATE	DESCRIPTION	DRAWING CODE
27-JAN-00	AMPLIFIER 10-11-12-13 GHz 1W	AP-13-CL



IN CASE OF THE AMPLIFIER DRIVING OTHER MODULES

POWER AMPLIFIER 10-11-12-13 GHz – 4W

TECHNICAL SPECIFICATIONS

FREQUENCY BAND	10200 / 10700 MHz 10700 / 11500 MHz 11700 / 12400 MHz 12700 / 13200 MHz
INPUT LEVEL	+ 29 dBm +/- 1 dBm
OUTPUT LEVEL	+ 36 dBm +/- 1 dBm
SATURATED OUTPUT POWER	> 36 dBm
INPUT CONNECTOR	SMA Female
INPUT RETURN LOSS	>10 dB
OUTPUT CONNECTOR	SMA Female
OUTPUT RETURN LOSS	>18 dB

CIRCUIT DESCRIPTION

The POWER AMPLIFIER 10-11-12-13GHz 4W supplies the power amplification of the signal coming out from the AMPLIFIER 10-11-12-13GHz 1W; it happens via a module equipped with a FET transistor (Q11). In output to this module there is inserted a RF detector. The signal for this detector is taken by a directional coupler integrated in the module. The continuous voltage level in output to the detector is amplified by IC2A and is sent to the link BUS via pin 10 of the REAR CONNECTOR.

The RF detector sensitivity adjustment could happen via RV3.

The positive supplies of the module are obtained directly from the voltage at 24V non stabilized via a switch of high efficiency (IC1).

The bias negative voltages are taken from the -15 volts present in the REAR CONNECTOR (pin 13) through a Zener diode stabilizer (D1).

The rotation of RV1 allows the correct value of the bias current required by Q11. This current can be read from the voltage drop, present across the reading resistance R21 (TP1/TP2).

For protecting the power RF transistors, the negative voltage is detected by IC2B, which interrupts the output of the positive switching regulator.

SETUP and ADJUSTMENT PROCEDURE

INSTRUMENTATION REQUIRED

- DC Voltmeter
- RF Generator
- Bolometer with attenuator

BIAS ADJUSTMENT

DC Voltmeter

connection

as prescribed in the adjustment section

Adjustment

Q11 bias

connect the voltmeter between TP1 and TP2
 adjust RV1 for a reading equal to:
 200mV (I = circa 1.8A) for Q11=TIM...
 120mV (I = circa 1.1A) for Q11=FLM...

RF DETECTOR SENSITIVITY ADJUSTMENT

DC Voltmeter

connection

positive to pin 10 of the REAR CONNECTOR
 negative to ground

RF Generatore

output level

see adjustment section

frequency

10500 MHz (10200 / 10700 MHz)
 11100 MHz (10700 / 11500 MHz)
 12000 MHz (11700 / 12400 MHz)
 13000 MHz (12700 / 13200 MHz)

connection

RF IN connector of the module

Bolometer

sensitivity

>5 Watt full scale

connection

RF OUT output of the module

Adjustment

- adjust the generator output level for getting a bolometer reading (output power) equal to +36 dBm
- Adjust RV3 in order to get a voltmeter reading equal to +4.5 V

CAVITY 1

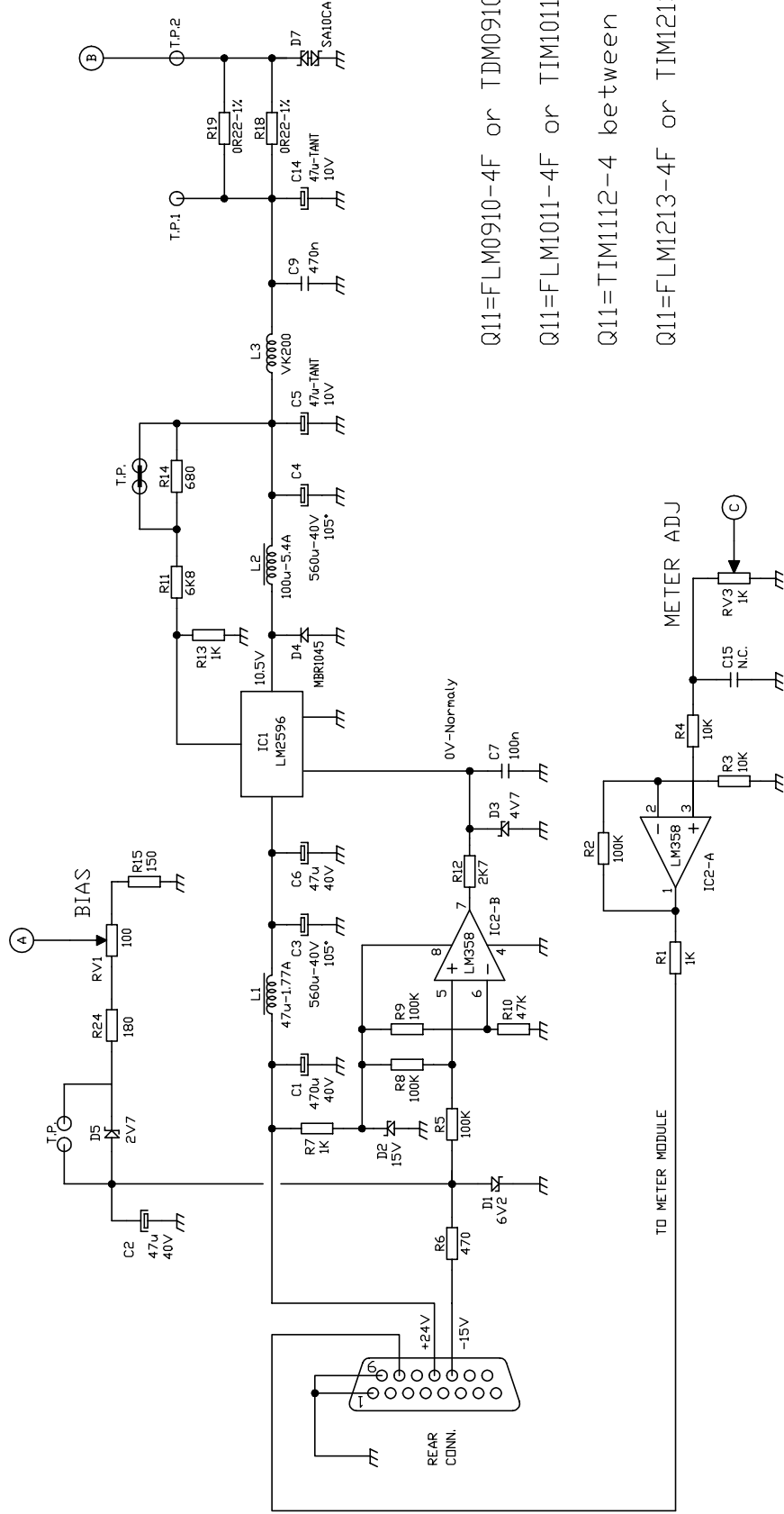
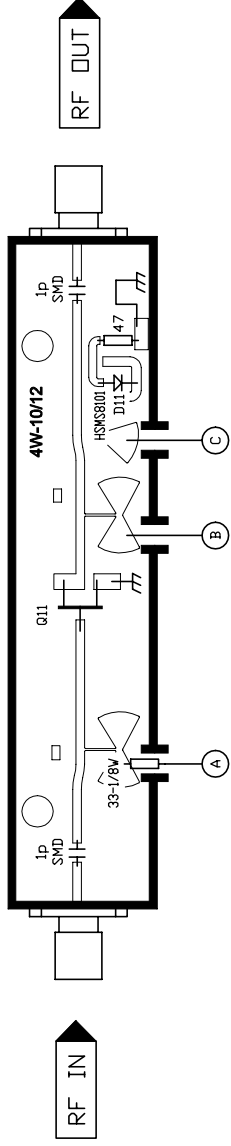

Q11=FLM0910-4F or TDM0910-4 between 9.5-10.5GHZ

Q11=FLM1011-4F or TIM1011-4 between 10.7-11.7GHZ

Q11=TIM1112-4 between 11.7-12.7GHZ

Q11=FLM1213-4F or TIM1213-4 between 12.7-13.2GHZ

ALL RESISTORS IF NOT OTHERWISE INDICATED: 1/4W - 5%
 ALL CAPACITORS IF NOT OTHERWISE INDICATED: TOLERANCE 5%



DATE	DESCRIPTION	DRAWING CODE
28-JAN-00	POWER AMPLIFIER 10-11-12-13GHZ 4W	PA-04-SC

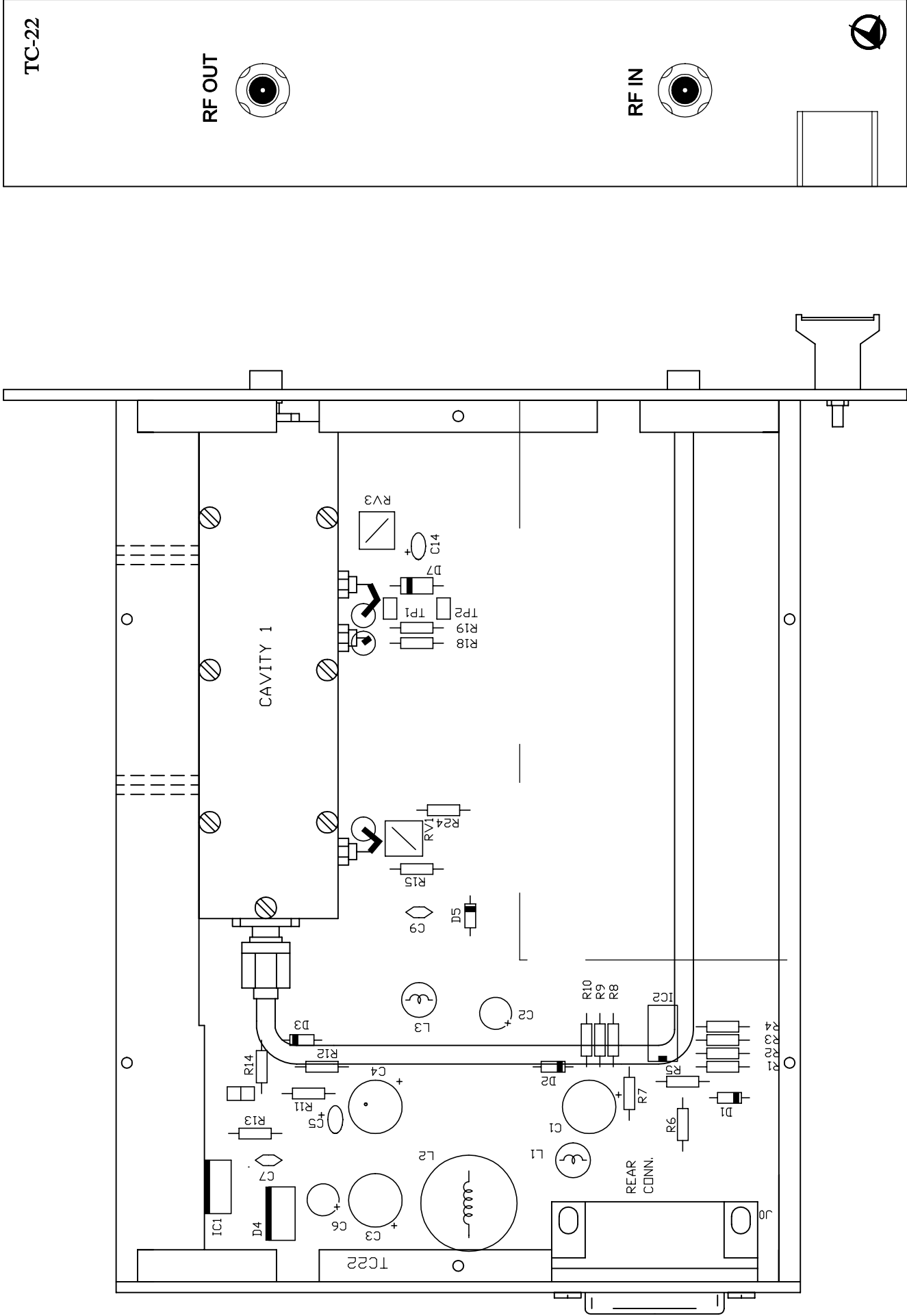

TC-22

RF OUT



RF IN



DATE
27-JAN-00

DESCRIPTION
POWER AMPLIFIER

10-12-13-14GHZ 4W

DRAWING CODE
PA-04-CL

SUPPLY

TECHNICAL SPECIFICATIONS

INPUT	230V AC +/-10% or 110V AC +/-5% 24V /30V DC negative to ground
INPUT SELECTION	automatic
OUTPUT	+24V @ 1A ; +15V @ 1A ; -15V @ 300 mA
PROTECTIONS	
AC INPUT	1.6A T fuse
DC INPUT	8A fuse
OUTPUTS	all outputs are electronically protected against short circuits towards ground.

CIRCUIT DESCRIPTION

The supply input voltage could be constituted by the rectified output of the main transformer or by a continuous nominal voltage source at 24 V.

The selection occurs simply on the basis of the level arriving to the diode bridges D3 and D4. This last ones will also prevent any reciprocal load.

The 24V voltage is generated by a linear stabilizer (IC2) fed by the voltage supplied by a CC/CC step up voltage converter (IC4).

The 15V voltage is obtained from the input continuous voltage via a voltage linear regulator (IC1).

The negative voltage -15V is produced by the switching supply made by IC3 and Q1.

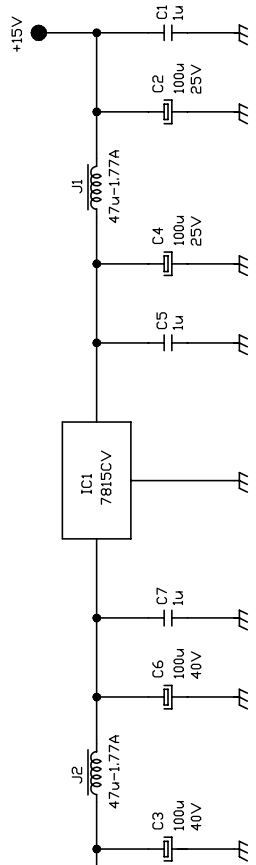
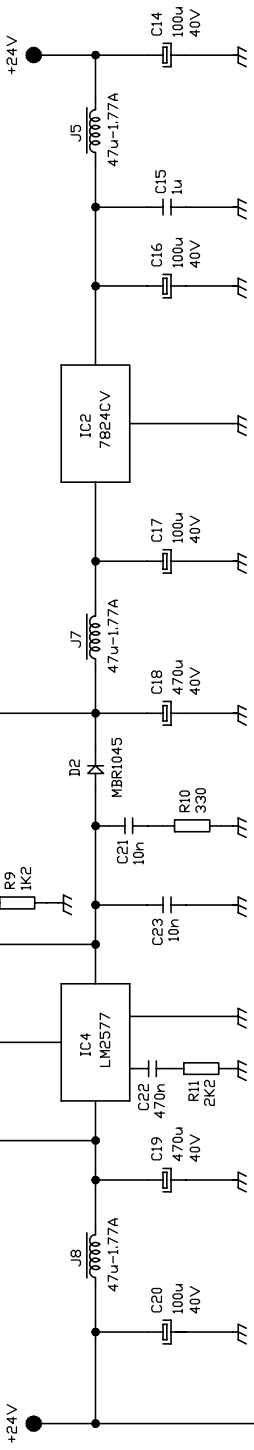
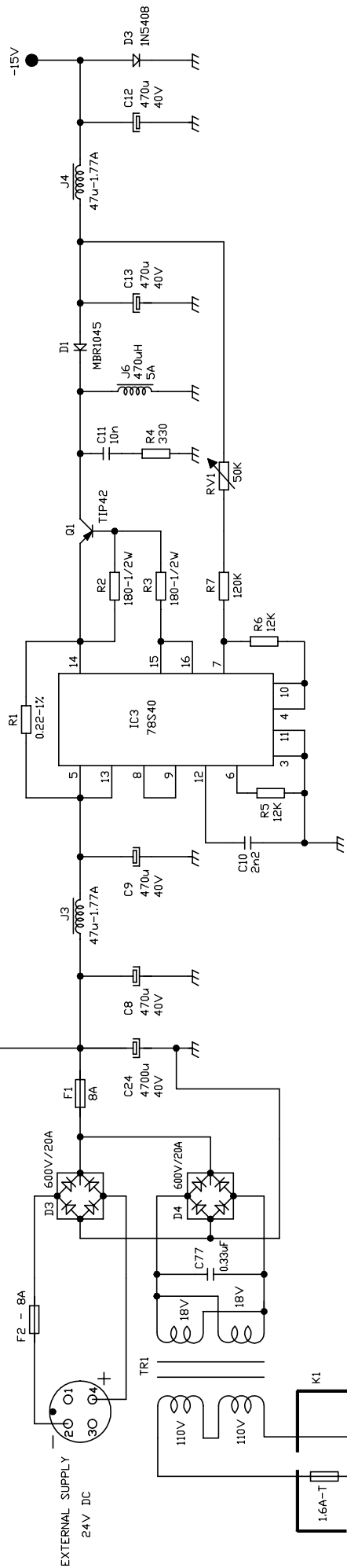
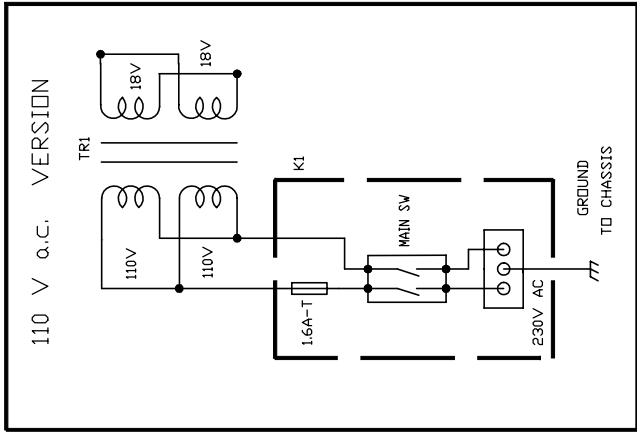

ALL RESISTORS IF NOT OTHERWISE INDICATED: 1/4W - 5%
 ALL CAPACITORS IF NOT OTHERWISE INDICATED: TOLERANCE 5%



DATE	DESCRIPTION	DRAWING CODE
03-JUL-99	POWER SUPPLY TMC	PS-03-SC

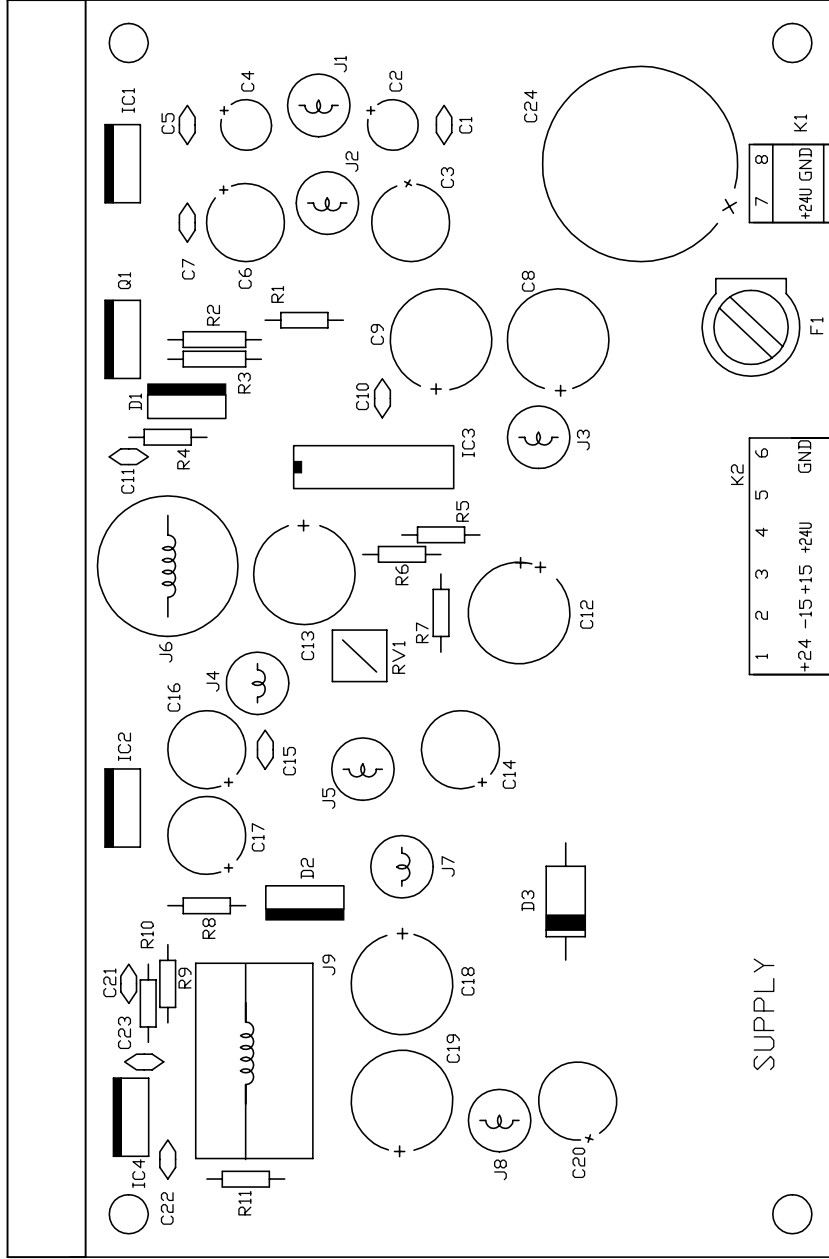

	DATE	DESCRIPTION	DRAWING CODE
	07-JUN-99	POWER SUPPLY TMC STABILIZATION BOARD	PS-06-CL

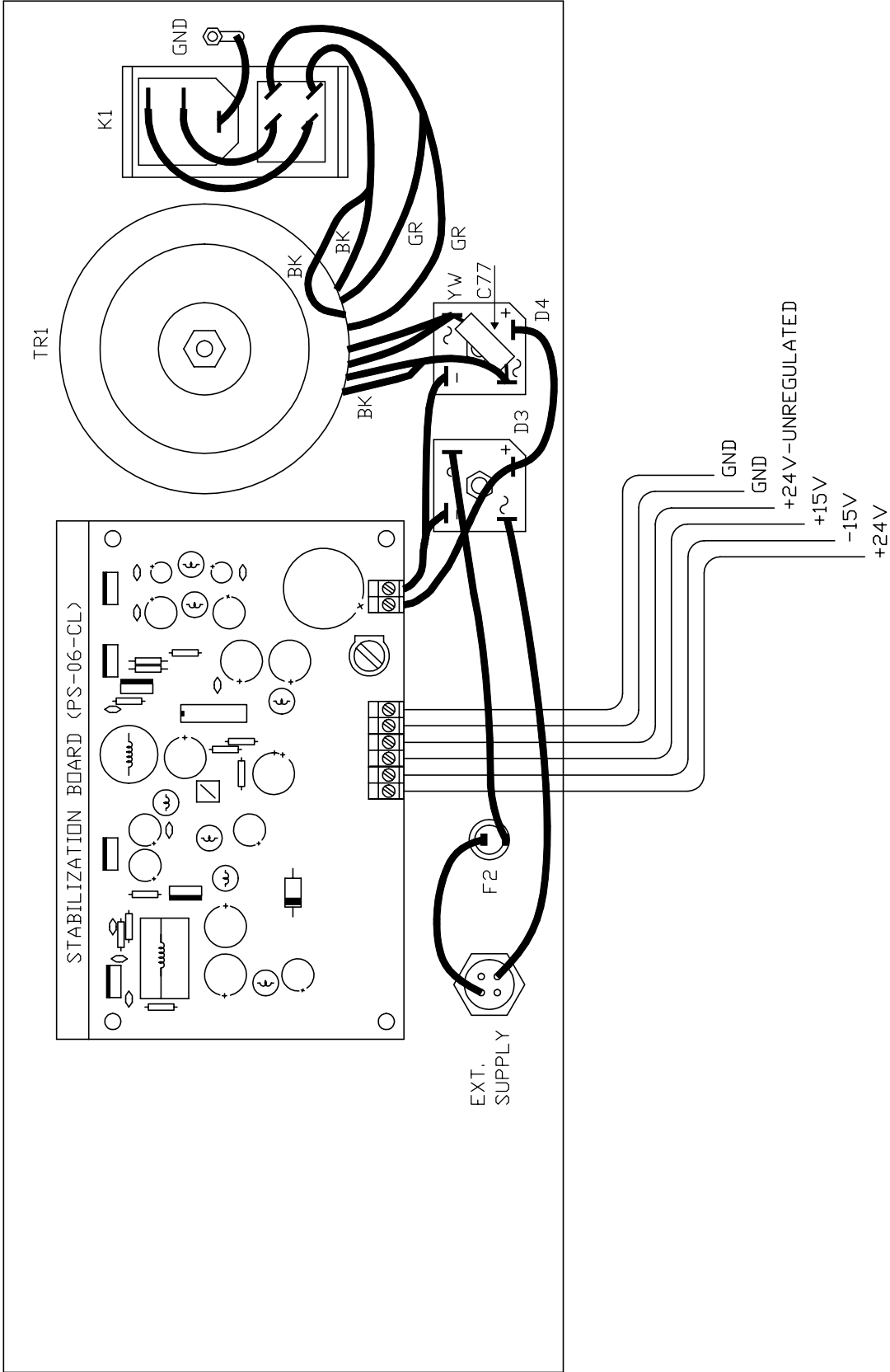

DATE	DESCRIPTION	DRAWING CODE
15-JUN-99	POWER SUPPLY TMC 110V - ASSY PANEL	PS-07-CL



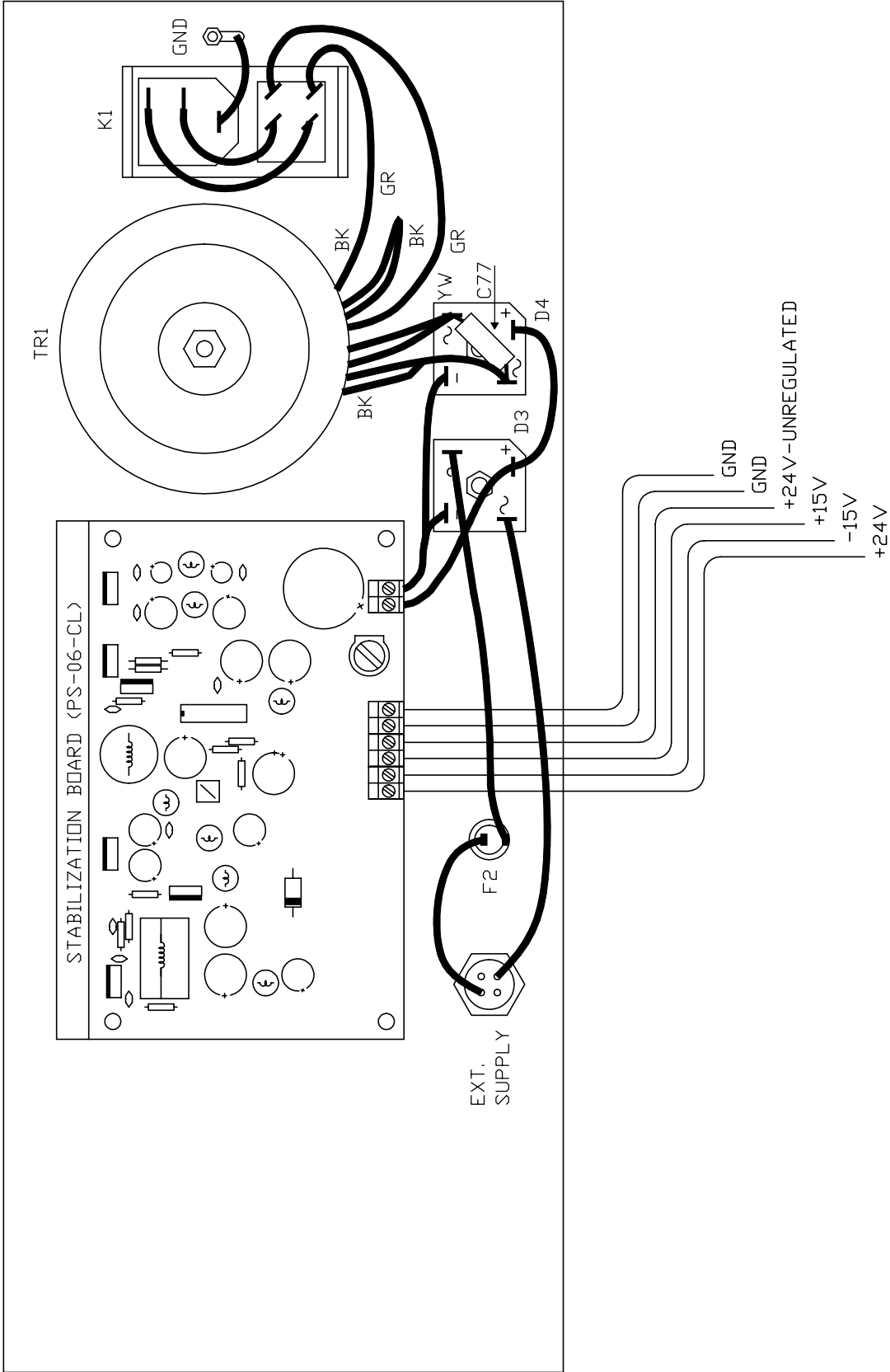

DATE	DESCRIPTION	DRAWING CODE
15-JUN-99	POWER SUPPLY TMC	PS-05-CL
	230V - ASSY PANEL	





TABLE OF CONTENTS

1 METER RTC-03	A
1.1 FRONT PANEL CONTROL	A
1.2 CONFIGURING THE METER	C
1.3 TRANSMITTER MAIN MENU OPTIONS	E
1.3.1 TRANSMITTER CONFIGURATION	F
1.3.2 TRANSMITTER STATUS	F
1.4 RECEIVER MAIN MENU OPTIONS	G
1.4.1 RECEIVER CONFIGURATION	G
1.4.2 RECEIVER STATUS	H
1.5 RS-485	H
1.6 REM METER	H

1 METER RTC-03

The RTC-03 manages and controls all communication performed within the equipment being analogue modulator/demodulator, transmitter or receiver. All controls are performed using the four way keypad and the LCD on the front panel. In addition, the RTC-03, displays status messages and parameter settings for installed modules. These parameters, apart from being displayed on the LCD, can also be accessed remotely via RS485 connection. The RF power (for a transmitter) or RF Field (for a receiver) also can be remotely accessed via an analogue signal.

1.1 FRONT PANEL CONTROL

<i>Control Item</i>	<i>Description</i>			
LCD	The LCD is a 12*2 alphanumeric display used to present all control and status messages from the embedded system.			
Four Way Keypad	The Four Way Keypad enables navigation through the various menus of the embedded system. Unless stated otherwise, the function of the keypad is as follows:			
	<i>Keypad</i>	<i>Configuration Menu</i>		<i>Status Menu</i>
		<i>Cursor Position 1</i>	<i>Other Cursor Position</i>	
	UP	Previous Menu	Increase Value	Previous Menu
DOWN	Next Menu	Decrease Value	Next Menu	

	SCROLL	Moves Cursor's Position one step to the right	Scrolls cursor's position one step to the right. If Position scrolls back to Position 1 any changes will be discarded and original values will be reloaded	Not used
	ENTER	Next Menu	Saves changes	Next Menu
REM METER	For pinout please refer to section 1.6			
RS485	For pinout please refer to section 1.5			
LINE	The LINE output is used to control Elber's External RF Head Units			
ALARM	The ALARM led can have two states: <ul style="list-style-type: none"> • OFF: No Alarm Present • ON: Some values are outside normal operation range. Please go through menus to check error. 			
ON	When the ON led is green, it indicates that the RTC-03 is switched on.			

1.2 CONFIGURING THE METER

Prior to use the RTC-03 for the first time, it is important to configure the system parameters depending on the modules installed. In order to access the Advanced Menu, please follow this simple procedure:

With the equipment switched off, press and hold the UP and DOWN buttons simultaneously. With the buttons still pressed, switch on the equipment until the display shows :

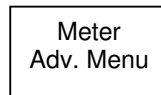

The hierarchy of the Advanced menu is shown in Figure 1.

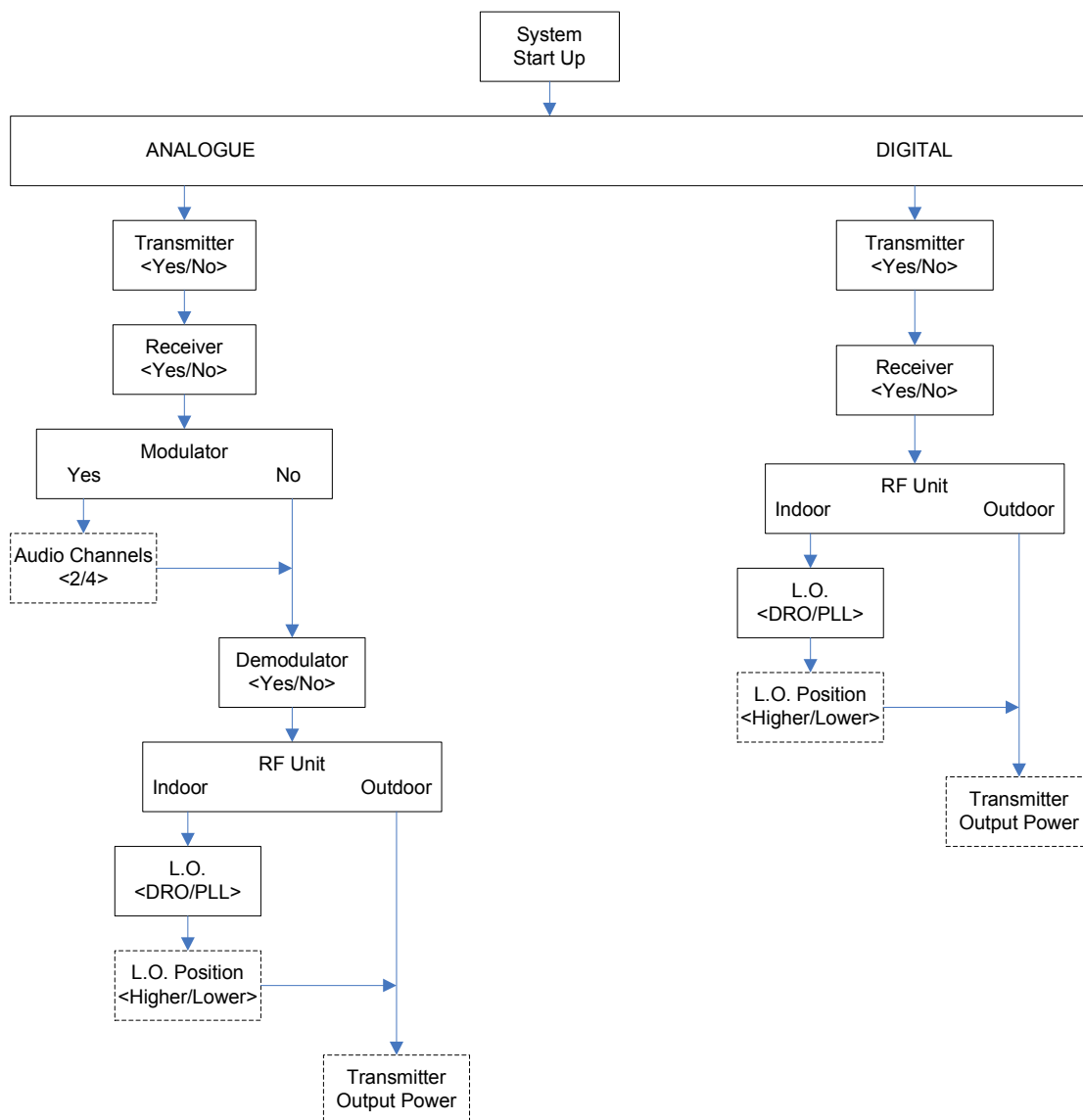

Figure 1: Tree of Advanced Menu

(Dotted menu indicates that availability of the option is dependent on the system parameters)

The navigation through menus is based on type of equipment meter needs to control, i.e. either analogue or digital.

Explanation of each menu follows:

Menu	Description
Transmitter <Yes/No>	Choose YES if equipment is a Transmitter, else choose NO.
Receiver <Yes/No>	Choose YES if equipment is a Receiver, else choose NO.
Modulator <Yes/No>	This menu item is only available for ANALOGUE equipment. Choose YES if equipment has Modulator installed, else choose NO.
Demodulator <Yes/No>	This menu item is only available for ANALOGUE equipment. Choose YES if equipment has Demodulator installed, else choose NO.
Audio Channels <2/4>	Choose 2 if Analogue Modulator has 2 Audio Channels installed else choose 4.
RF Unit <Indoor/Outdoor>	This parameter indicates type of RF head used, either Indoor (i.e. a single rack) or Outdoor (i.e. two separate racks connected via IF signal).
L.O. <DRO/PLL>	The Local Oscillator installed can either be free-running or synthesized. Choose: DRO if its free-running, and PLL if local oscillator if synthesized
L.O. Position <Higher/Lower>	Local Oscillator can either be Higher or Lower to the Microwave Radio Link's Frequency.
Transmitter Output Power	Transmitter's Nominal Output Power should be selected from available levels in order to display the correct value of output power.

On exiting the Advanced Menu, the user will be asked whether or not he wants to save changes performed. Choosing YES all new values for system parameters are saved, otherwise all changed values are discarded and previous system parameters are reloaded. The system parameters are stored on an external EEPROM.

After switching on the equipment and the system is ready from the initial tests and configuration, the equipment will present the Main Status Display on the LCD.

1.3 TRANSMITTER MAIN MENU OPTIONS

The hierarchy of the Transmitter's Main menu is shown in Figure 2.

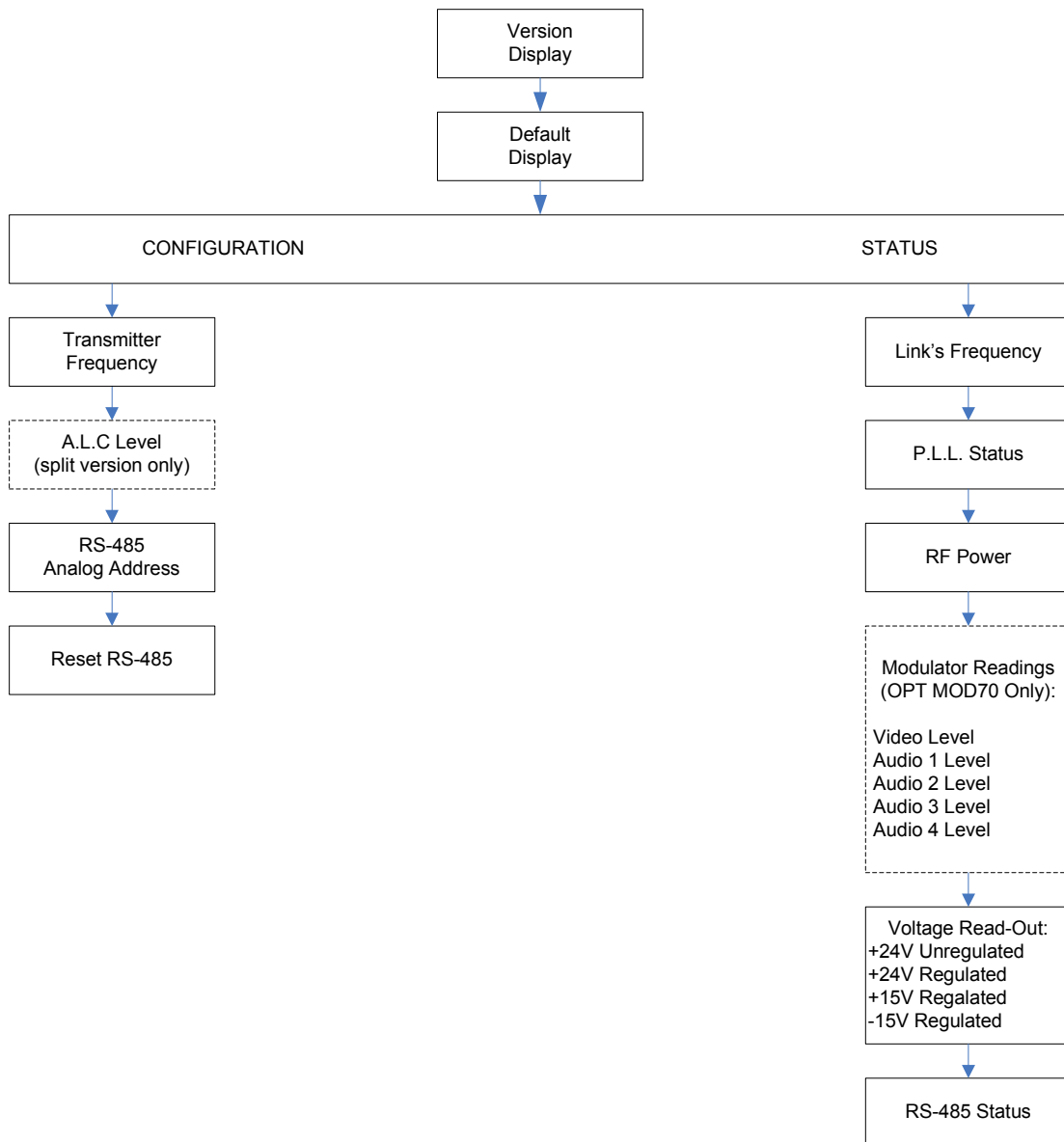

Figure 2: Tree of Transmitter Main Menu

Explanation of each menu follows:

1.3.1 TRANSMITTER CONFIGURATION

Menu	Description
Transmitter Frequency	The frequency of Transmitter can be changed within predefined limits
ALC level (split version only)	The value of back-off for the output power can be changed (0÷15 dB)
RS-485 analog address	Antenna Nord Protocol The value for the RS-485 address ranges from 1 to 32 can be changed
Reset RS-485	Reset counter of the communication errors on RS-485

1.3.2 TRANSMITTER STATUS

Menu	Description
Link's frequency	The frequency of apparatus is displayed
P.L.L. Status	Status: LOCK: P.L.L. Locked UNLOCK: P.L.L. Unlocked N/A: Communication with P.L.L. lost
RF power	The RF power of apparatus is displayed
Modulator Readings (OPT MOD70 only)	These menus display: Video Level Power Audio 1 Level Power Audio 2 Level Power Audio 3 Level Power Audio 4 Level Power
Voltage Read-Out	The operating voltages of apparatus are displayed
RS-485 Status	A summary of address in use, communication and parity errors is displayed

1.4 RECEIVER MAIN MENU OPTIONS

The hierarchy of the Receiver's Main menu is shown in Figure 3.

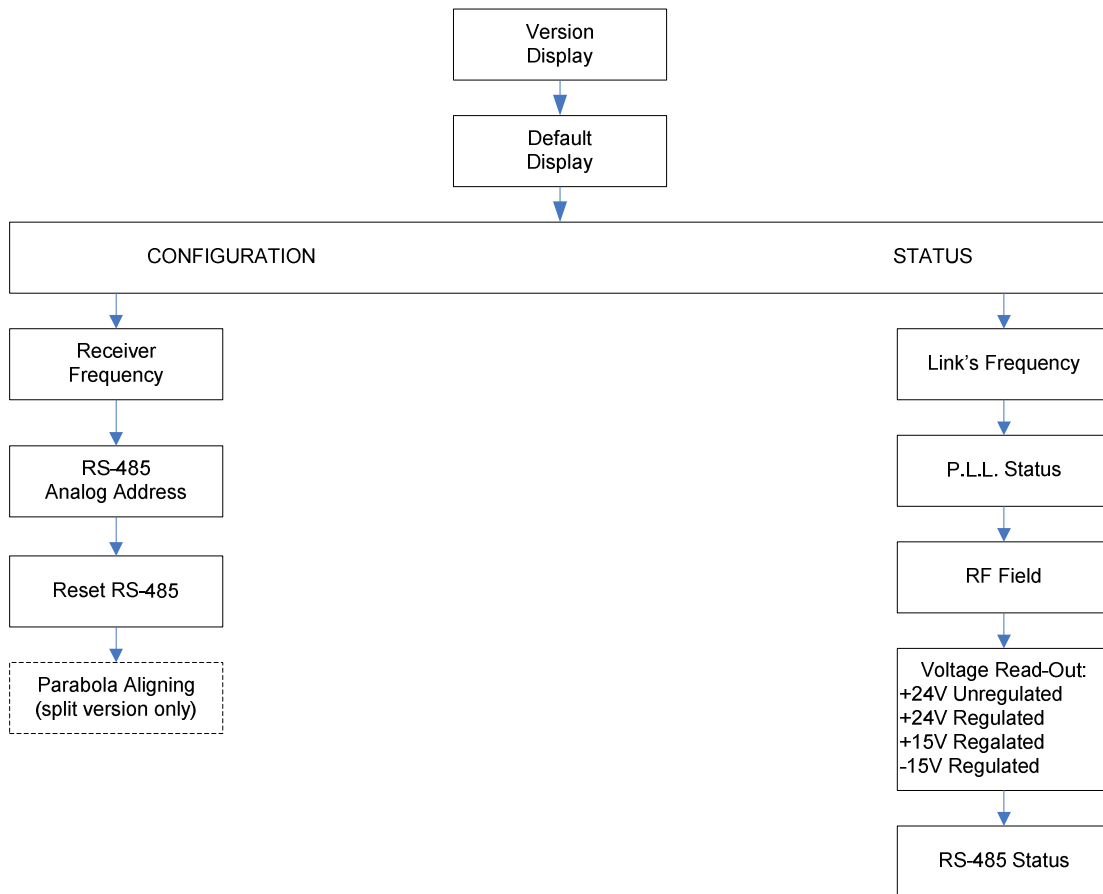

Figure 3: Tree of Receiver Main Menu

Explanation of each menu follows:

1.4.1 RECEIVER CONFIGURATION

Menu	Description
Receiver Frequency	The frequency of Receiver can be changed
RS-485 analog address	Antenna Nord Protocol The value for the RS-485 address ranges from 1 to 32 can be changed
Reset RS-485	Reset counter of the communication errors on

	RS-485
Parabola Aligning (Split version only)	Continuous refresh of Receiver's RF field in split version is performed. Press Enter to exit from this menu

1.4.2 RECEIVER STATUS

Menu	Description
Link's frequency	The frequency of apparatus is displayed
P.L.L. Status	Status: LOCK: P.L.L. Locked UNLOCK: P.L.L. Unlocked N/A: Communication with P.L.L. lost
RF field	The Receiver's RF field is displayed
Voltage Read-Out	The operating voltages of apparatus are displayed
RS-485 Status	A summary of address in use, communication and parity errors is displayed

1.5 RS-485

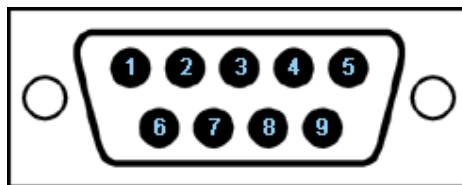

Figure 4: RS 485 9 pin connectors

PIN 1 A
PIN 2 B
PIN 9 GND

PIN 3-4-5-6-7-8 not used.

1.6 REM METER

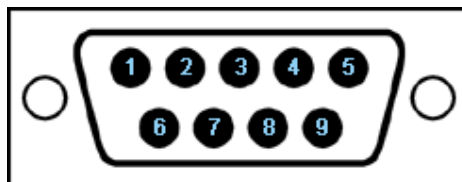
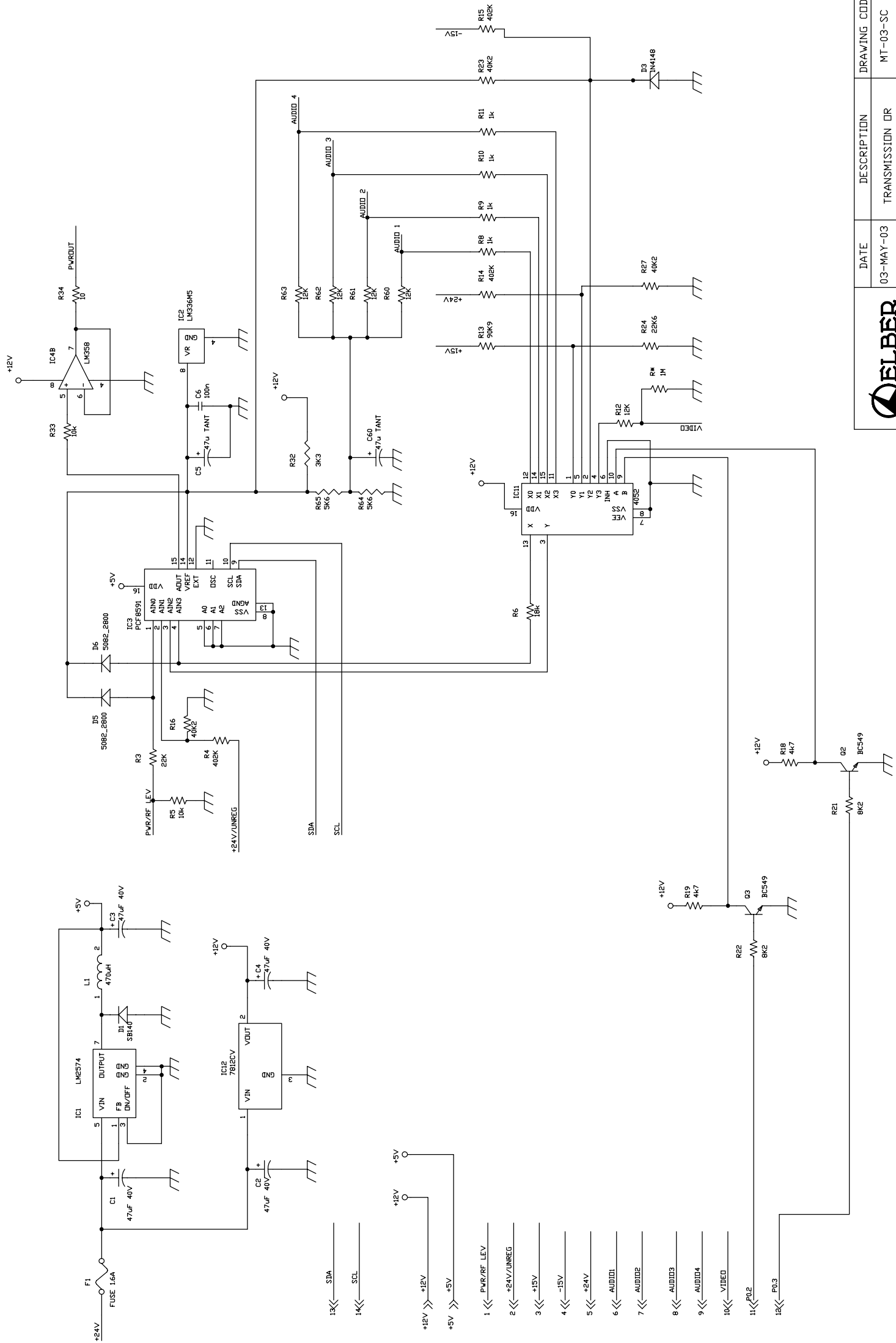

Figure 5: REM METER 9 pin connectors

PIN 1 : analogue voltage 0-5V that corresponds to the output RF power (Tx) or the received RF field (Rx)

PIN 3: indicates the presence of the video's pilot signal available in the analogue demodulators

PIN 5 : GND



	DATE	DESCRIPTION	DRAWING CODE
	03-MAY-03	TRANSMISSION OR RECEPTION METER	MT-03-SC

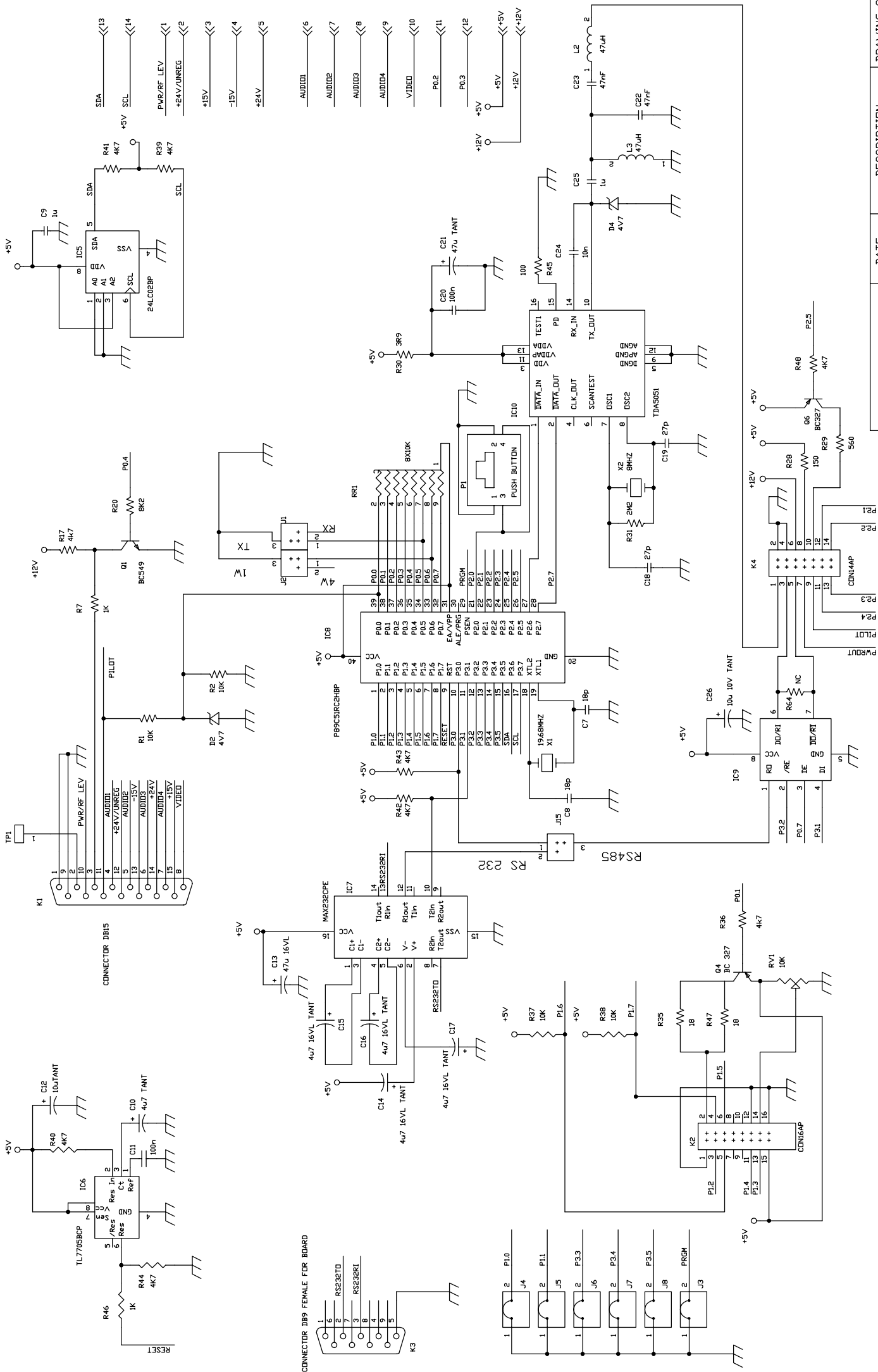

	DATE	DESCRIPTION	DRAWING CODE
	03-MAY-03	TRANSMISSION OR RECEPTION METER	MT-04-SC

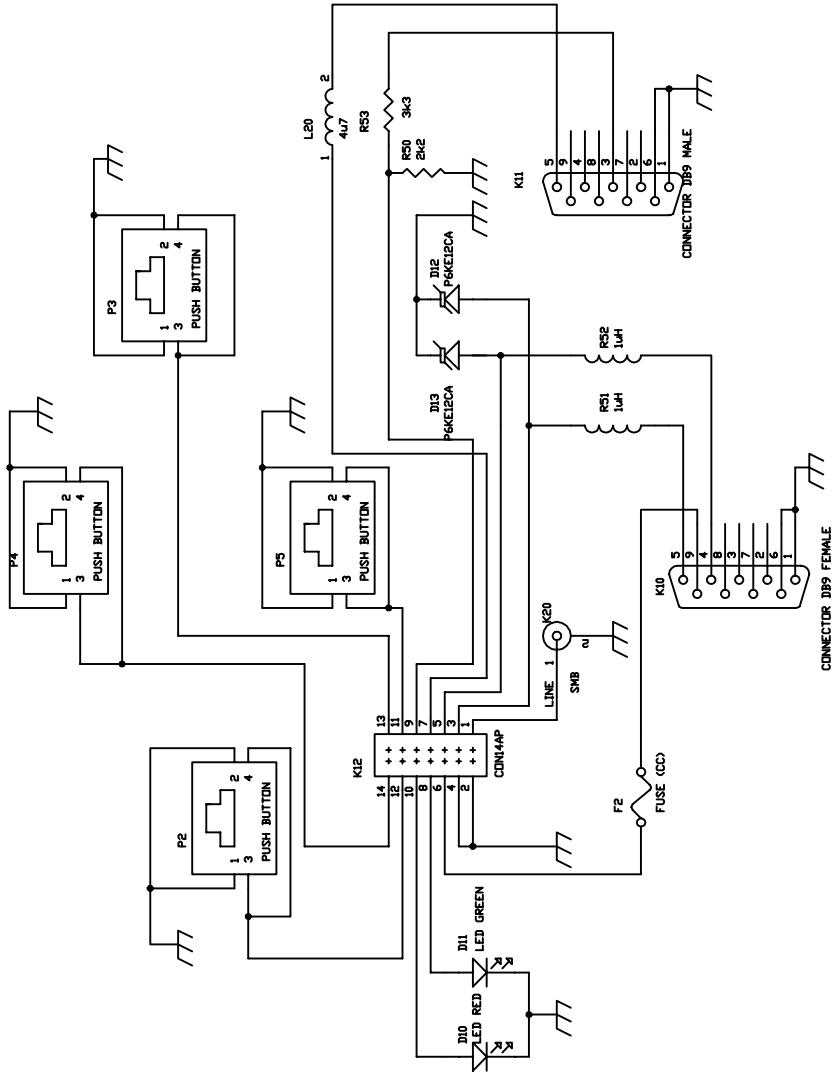

	DATE	DESCRIPTION	DRAWING CODE
	03-MAY-03	TRANSMISSION OR RECEPTION METER	MT-05-SC

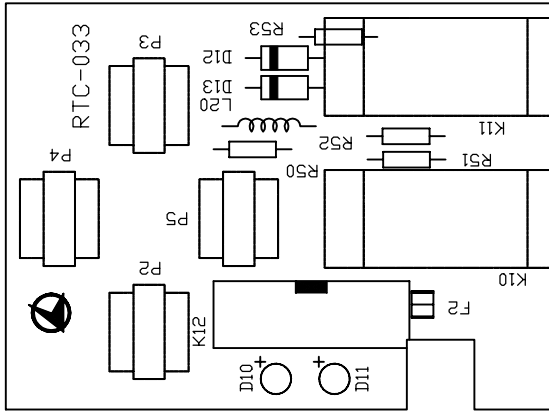
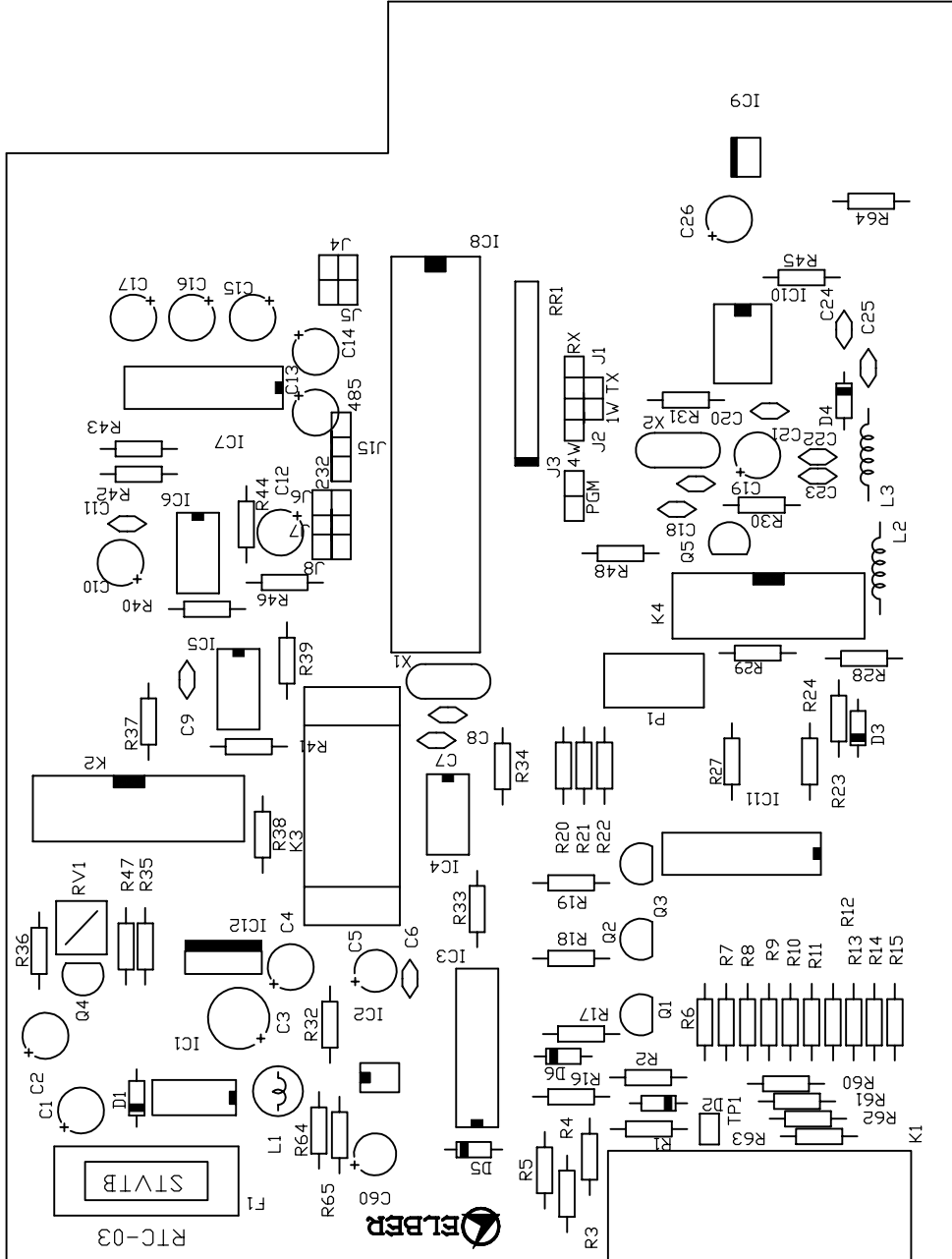

ELBER	DATE	DESCRIPTION	DRAWING CODE
	25-MAY-03	TRANSMISSION OR RECEPTION METER	MT-05-CL

RTC-03

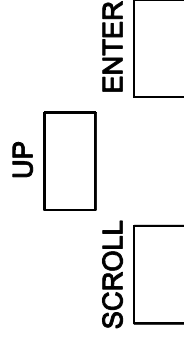

● ALARM

● ON



LINE

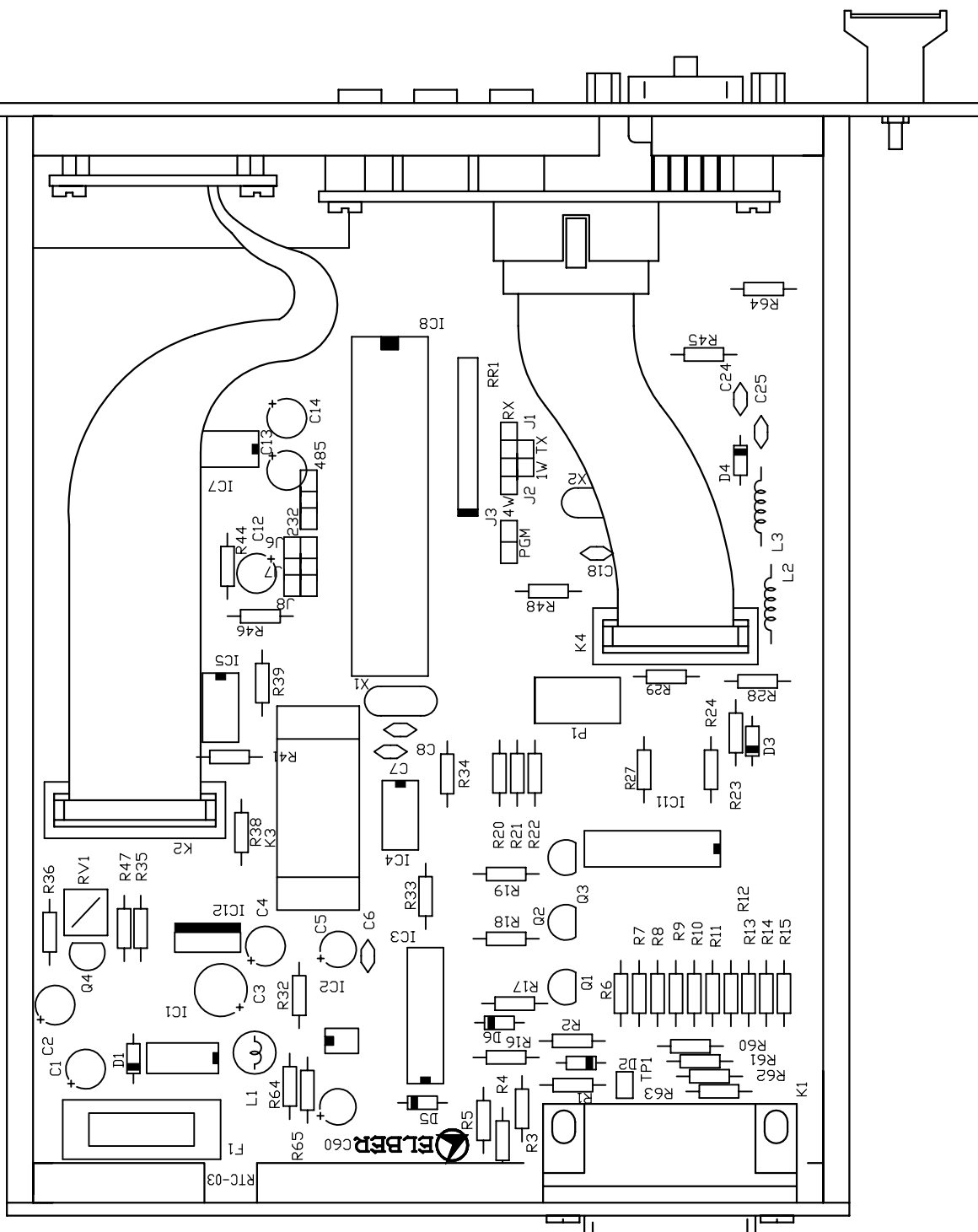
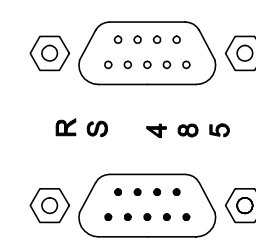

ELBER	DATE	25-MAY-03	DESCRIPTION	TRANSMISSION OR RECEPTION METER	DRAWING CODE	MT-06-CL

AUDIO 3 and 4 DEMODULATOR

TECHNICAL SPECIFICATIONS

SUBCARRIER FREQUENCY AUDIO 3	7020 KHz
SUBCARRIER FREQUENCY AUDIO 4	8590 KHz
NOMINAL INPUT LEVEL	
SUBCARRIER INPUT LEVEL	-14 dBm (50 mv eff) on 75 OHM
INPUT MATCHING	< -20 dB
DEEMPHASIS	50 usec (could be excluded by internal jumper)
AUDIO BANDWIDTH (@ 1dB)	15 KHz
TOTAL HARMONIC DISTORSION	< 0.5%
S/N WEIGHTED	> 64 dB with deviation of 70 KHz
AUDIO OUTPUT LEVEL	predisposed through internal jumpers at 0dBm, +3dBm, +6dBm, +9dBm
AUDIO OUTPUT IMPEDANCE	25 OHM electronically balanced or 600 OHM electronically balanced.

CIRCUIT DESCRIPTION

The signal constituted by all the audio subcarriers with level equal to -14dBm (frequency 7020 KHz, 7500 KHz, 8065 KHz or 8590 KHz) is applied to the input connector SC IN. The same signals are on the connector SC OUT of the same module (connected in parallel to the input connector SC IN).

The signal is taken via an emitter follower stage at high input impedance (Q1).

The DEMODULATOR AUDIO 3 / 4 provides the demodulation of the subcarriers Audio 3 and Audio 4 (frequency 7020 KHz and 8590 KHz) after the necessary filtering, made by narrow band (300 KHz at 1db) elliptical filters.

The integrated circuits IC1 and IC2 provide the signal limitation and the frequency discrimination of subcarriers audio 3 and audio 4 respectively.

The discriminators are a "quadrature" type and work in the frequency at which the networks are tuned, including L5 and L6 (7020 KHz) and L9 and L10 (8590 KHz).

The signal (Audio 3), demodulated by IC1, is applied to IC3B input, which provides the deemphasis. If is required the deemphasis could be excluded by J5.

The signal Audio 3 is filtered by a low pass filter with a notch at 15625 KHz (L8, C28) and amplified by IC3A, which gain could be increased 9 dB at steps of 3 dB, moving sequentially jumper J6 from the connection with R15 to the one with R16, R17 or R18.

Finally, the integrated circuit IC5 provides the output balance of the Audio 3 signal.

To obtain an audio output impedance equal to 600 OHM, the resistencies R21 and R22 must be connected (jumpers J7 and J8 in position H) in serie to the IC5 output terminals.

The signal (Audio 4), demodulated by IC2, is applied to the IC4B input, which provides the deemphasis. If is required, this function (deemphasis) could be excluded by J1.

The signal Audio 4 is filtered by a low pass filter with a notch at 15625 KHz (L13, C46) and amplified by IC4A, which gain could be increased 9 dB at steps of 3 dB, moving sequentially jumper J2 from the connection with R36 to the one with R37, R38 or R39.

Finally, the integrated circuit IC6 provides the output balance of the Audio 4 signal.

To obtain an audio output impedance equal to 600 OHM, the resistencies R41 and R42 must be connected (jumpers J3 and J4 in position H) in serie to the IC6 output terminals.

SETUP and ADJUSTMENT PROCEDURE

INSTRUMENTS REQUIRED

- RF sweeper
- RF detector with display XY
- Audio generator
- Audio analyzer
- RF generator modulabile FM

BAND PASS ADJUSTMENT OF SUBCARRIER FILTER 7020 KHz

Sweeper

Central frequency

7020 KHz

deviation

1 Mhz pp

level

0 dBm on 75 OHM

connection

input SC IN of the module

RF detector

Impedance

> 1 MOHM (with C in < 10 pf)

Connection

J9

Adjustment

L12, L16, L18, L15 and L17 to reproduce the curve of figure1 (max. level = 70 mV eff approx.)

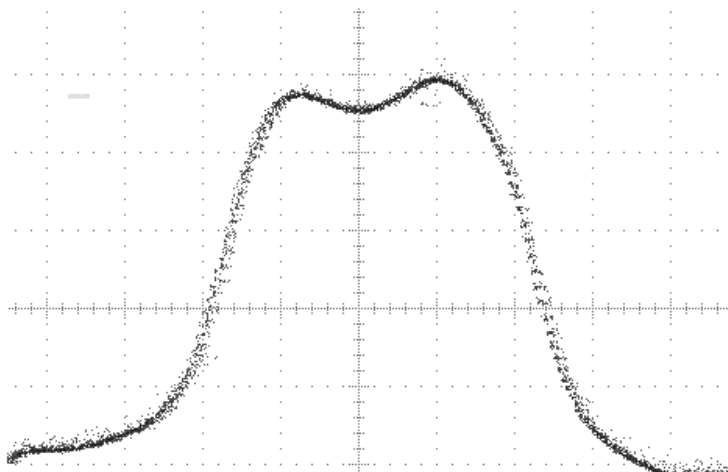

Figure 1

BAND PASS ADJUSTMENT OF SUBCARRIER FILTER 8590 KHz**Sweeper**

Central frequency	8590 KHz
deviation	1 Mhz pp
level	0 dBm on 75 OHM
connection	input SC IN of the module

RF detector

Impedance	> 1 MOHM (with C in < 10 pf)
Connexion	J10
Jumpers	J1: xx J2: xx J3: xx J4: xx J5: xx J6: xx J7: xx J8: xx
Adjustment	L14, L1, L2, L3 and L4 to reproduce the curve of figure 2 (max. level = 70 mV eff approx.)

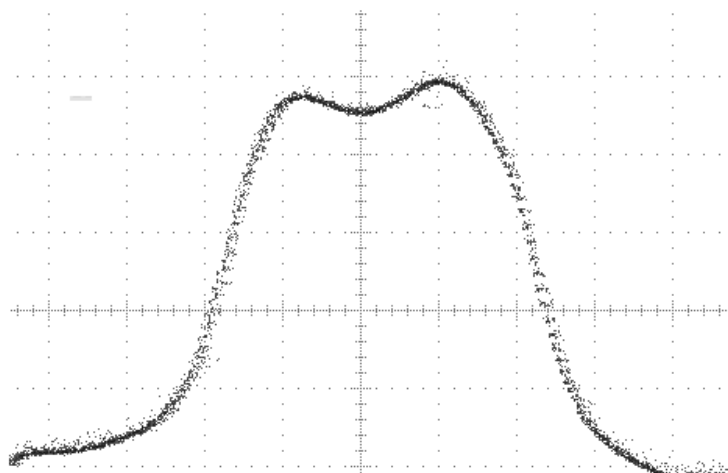
*Figure 2***AUDIO 3 LEVEL & DISCRIMINATOR LINEARITY ADJUSTMENT****FM RF generator**

Central frequency	7020 KHz
level	-30 dBm on 75 OHM
modulation frequency	3 KHz
deviation	250 KHz pp
Connection	input SC IN of the module

Audio analyzer

Connection	output AUDIO 3 of the module
Jumpers	J5: on J6: pos 9 (dBm) J7: L J8: L

Adjustment

L5 and L6 to obtain an harmonic distortion level less that 0.5%
RV1 for an output level equal to +9dBm

AUDIO 4 LEVEL & DISCRIMINATOR LINEARITY ADJUSTMENT**FM RF generator**

Central frequency 8590 KHz
level -14dBm on 75 OHM
modulation frequency 3 KHz
deviation 250 KHz pp
Connection input SC IN of the module

Audio analyzer

Connection output AUDIO 4 of the module
Jumpers J1: on J2: pos 9 (dBm) J3: L J4: L
Adjustment L9 and L10 to obtain an harmonic distortion level less that 0.5%
RV2 for an output level equal to +9dBm

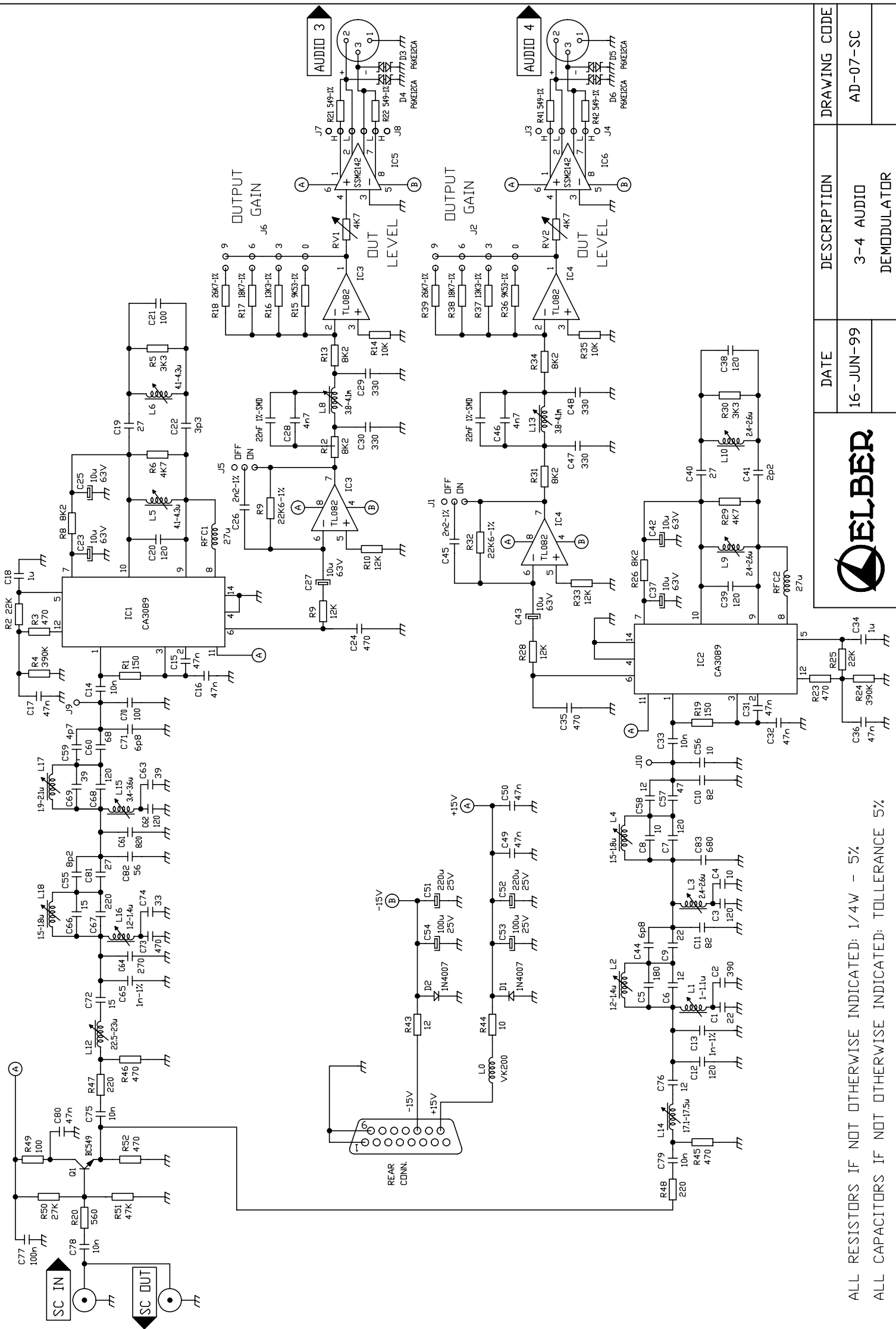

ALL RESISTORS IF NOT OTHERWISE INDICATED: 1/4W - 5%
 ALL CAPACITORS IF NOT OTHERWISE INDICATED: TOLERANCE 5%

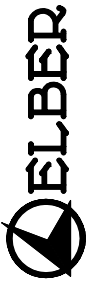

DATE	16-JUN-99
------	-----------

DESCRIPTION	3-4 AUDIO DEMODULATOR
-------------	-----------------------

DRAWING CODE	AD-07-SC
--------------	----------

RC-04

AUDIO 4

AUDIO 3

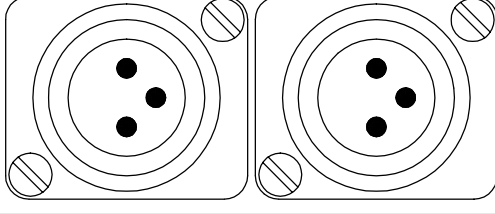

SC IN

SC OUT

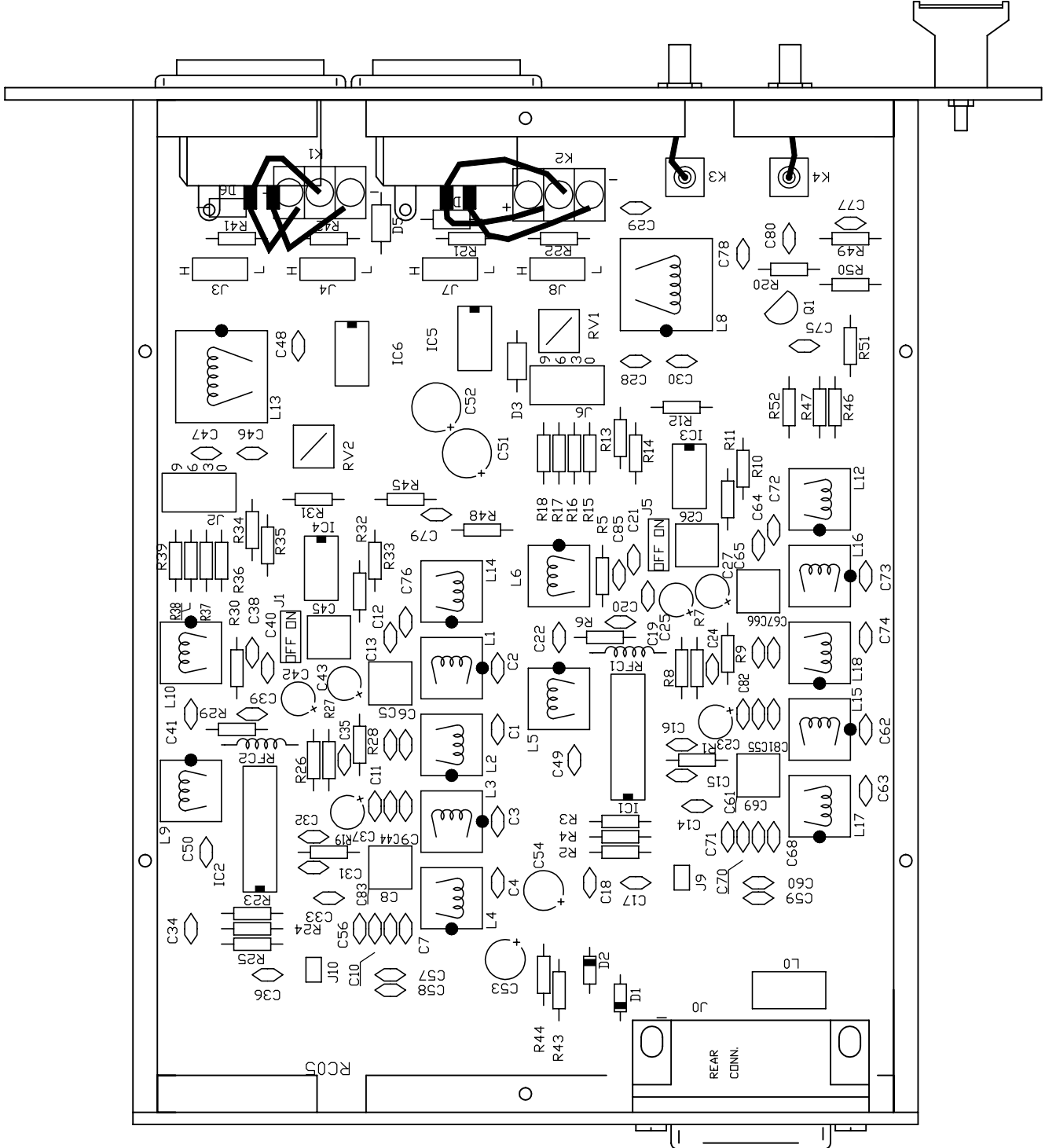

DATE	DESCRIPTION	DRAWING CODE
25-MAY-99	AUDIO 3/4 DEMODULATOR	AD-11-CL



COMPONENT LAYOUT VALID FOR
MODULAR AND "SLIM LINE" SERIE

AUDIO 1 and 2 DEMODULATOR

TECHNICAL SPECIFICATIONS

SUBCARRIER FREQUENCY AUDIO 1	7500 KHz
SUBCARRIER FREQUENCY AUDIO 2	8065 KHz
NOMINAL INPUT LEVEL	
SUBCARRIER INPUT LEVEL	-14 dBm (50 mv eff) on 75 OHM
INPUT MATCHING	< -20 dB
DEEMPHASIS	50 usec (could be excluded by internal jumper)
AUDIO BANDWIDTH (@ 1dB)	15 KHz
TOTAL HARMONIC DISTORSION	< 0.5%
S/N WEIGHTED	> 64 dB with deviation of 70 KHz
AUDIO OUTPUT LEVEL	predisposed through internal jumpers at 0dBm, +3dBm, +6dBm, +9dBm
AUDIO OUTPUT IMPEDANCE	25 OHM electronically balanced or 600 OHM electronically balanced.

CIRCUIT DESCRIPTION

The signal constituted by all the audio subcarriers with level equal to -14dBm (frequency 7020 KHz, 7500 KHz, 8065 KHz or 8590 KHz) is applied to the input connector SC IN. The same signals are on the connector SC OUT of the same module (connected in parallel to the input connector SC IN).

The signal is taken via an emitter follower stage at high input impedance (Q1).

The DEMODULATOR AUDIO 1 / 2 provides the demodulation of the subcarriers Audio 1 and Audio 2 (frequency 7500 KHz and 8065 KHz) after the necessary filtering, made by narrow band (300 KHz at 1db) elliptical filters.

The integrated circuits IC1 and IC2 provide the signal limitation and the frequency discrimination of subcarriers audio 1 and audio 2 respectively.

The discriminators are a "quadrature" type and work in the frequency at which the networks are tuned, including L5 and L6 (7500 KHz) & L9 and L10 (8065 KHz).

The signal (Audio 1), demodulated by IC1, is applied to IC3B input, which provides the deemphasis. If is required the deemphasis could be excluded by J5.

The signal Audio 1 is filtered by a low pass filter with a notch at 15625 KHz (L8, C28) and amplified by IC3A, which gain could be increased 9 dB at steps of 3 dB, moving sequentially jumper J6 from the connection with R15 to the one with R16, R17 or R18.

Finally, the integrated circuit IC5 provides the output balance of the Audio 1 signal.

To obtain an audio output impedance equal to 600 OHM, the resistencies R21 and R22 must be connected (jumpers J7 and J8 in position H) in serie to the IC5 output terminals.

The signal (Audio 2), demodulated by IC2, is applied to the IC4B input, which provides the deemphasis. If is required, this function (deemphasis) could be excluded by J1.

The signal Audio 2 is filtered by a low pass filter with a notch at 15625 KHz (L13, C46) and amplified by IC4A, which gain could be increased 9 dB at steps of 3 dB, moving sequentially jumper J2 from the connection with R36 to the one with R37, R38 or R39.

Finally, the integrated circuit IC6 provides the output balance of the Audio 2 signal.

To obtain an audio output impedance equal to 600 OHM, the resistencies R41 and R42 must be connected (jumpers J3 and J4 in position H) in serie to the IC6 output terminals.

SETUP and ADJUSTMENT PROCEDURE

INSTRUMENTS REQUIRED

- RF sweeper
- RF detector with display XY
- Audio generator
- Audio analyzer
- RF generator modulabile FM

BAND PASS ADJUSTMENT OF SUBCARRIER FILTER 7500 KHz

Sweeper

Central frequency

7500 KHz

deviation

1 MHz pp

level

0 dBm on 75 OHM

connection

input SC IN of the module

RF detector

Impedance

> 1 MOHM (with C in < 10 pf)

Connection

J9

Adjustment

L12, L16, L18, L15 and L17 to reproduce the curve of figure1 (max. level = 70 mV eff approx.)

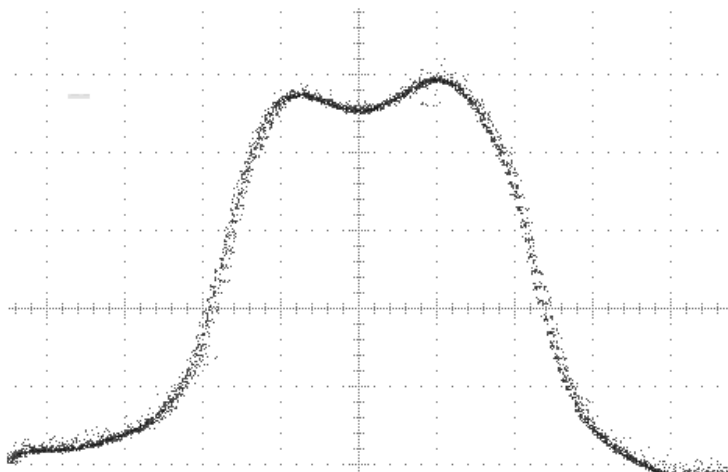

Figure 1

BAND PASS ADJUSTMENT OF SUBCARRIER FILTER 8065 KHz**Sweeper**

Central frequency	8065 KHz
deviation	1 MHz pp
level	0 dBm on 75 OHM
connection	input SC IN of the module

RF detector

Impedance	> 1 MOHM (with C in > 10 pf)
Connexion	J10
Adjustment	L14, L1, L2, L3 and L4 to reproduce the curve of figure 2 (max. level = 70 mV eff approx.)

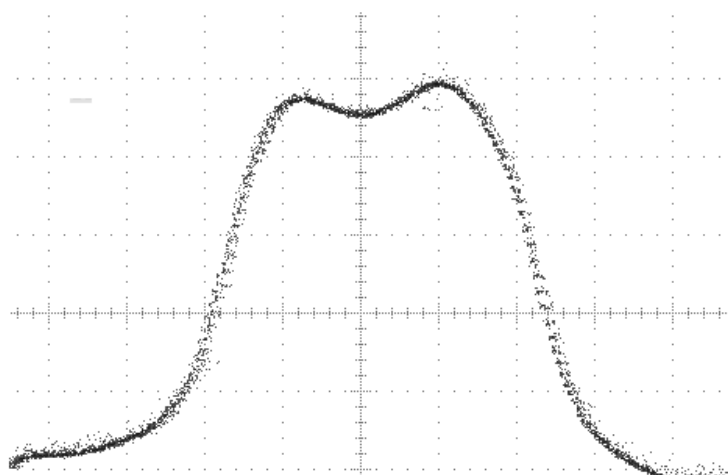
*Figure 2***AUDIO 1 LEVEL & DISCRIMINATOR LINEARITY ADJUSTMENT****FM RF generator**

Central frequency	7500 KHz
level	-30 dBm on 75 OHM
modulation frequency	3 KHz
deviation	250 KHz pp
Connection	input SC IN of the module

Audio analyzer

Connection	output AUDIO 1 of the module
Jumpers	J5: on J6: pos 9 (dBm) J7: L J8: L

Adjustment

L5 and L6 to obtain an harmonic distortion level less that 0.5%
RV1 for an output level equal to +9dBm

AUDIO 2 LEVEL & DISCRIMINATOR LINEARITY ADJUSTMENT

FM RF generator

Central frequency 8065 KHz
level -30 dBm on 75 OHM
modulation frequency 3 KHz
deviation 250 KHz pp
Connection input SC IN of the module

Audio analyzer

Connection output AUDIO 2 of the module
Jumpers J1: on J2: pos 9 (dBm) J3: L J4: L

Adjustment

- L9 and L10 to obtain an harmonic distortion level less that 0.5%
- RV2 for an output level equal to +9dBm

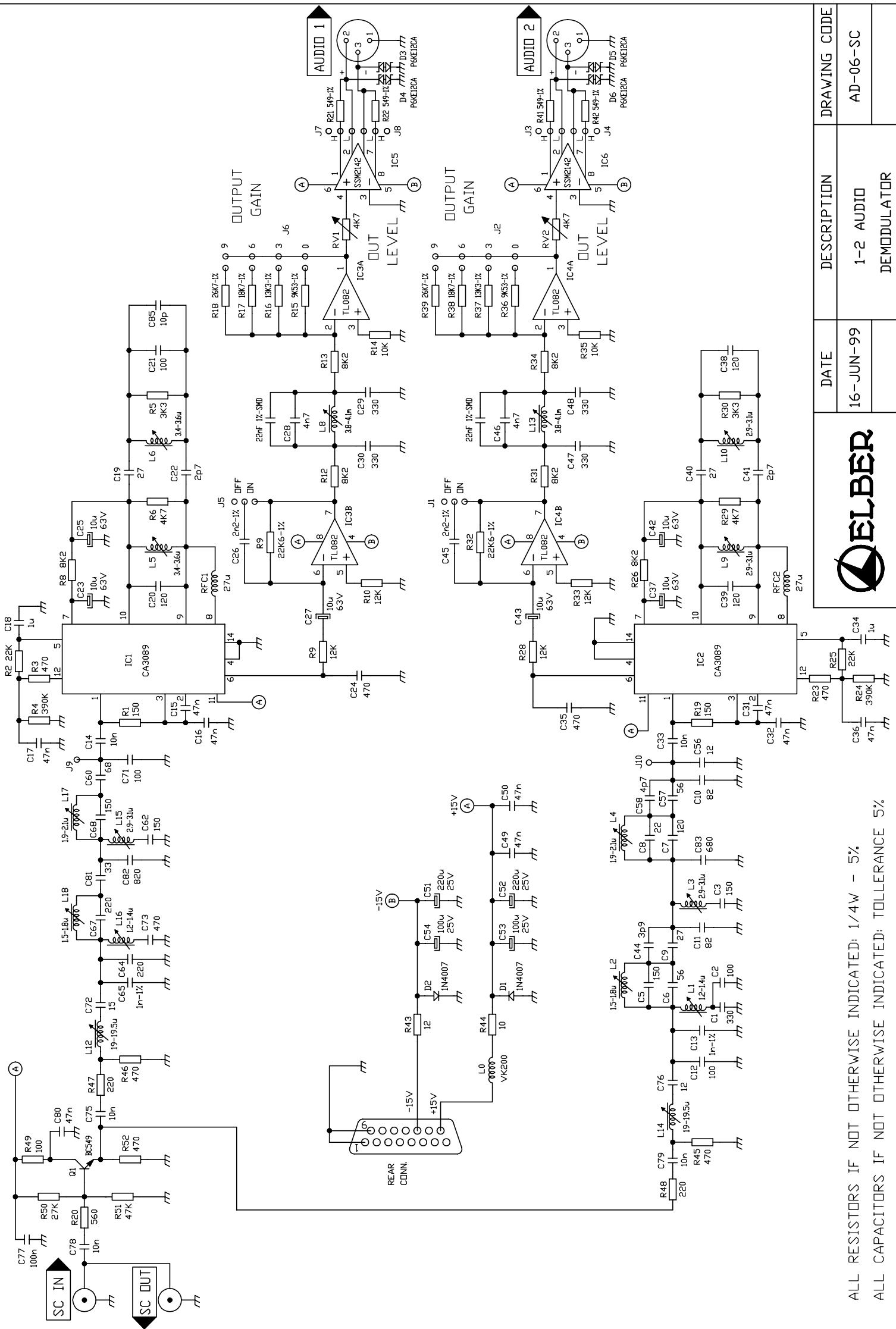

DATE	DESCRIPTION	DRAWING CODE
16-JUN-99	1-2 AUDIO DEMODULATOR	AD-06-SC

ALL RESISTORS IF NOT OTHERWISE INDICATED: 1/4W - 5%
 ALL CAPACITORS IF NOT OTHERWISE INDICATED: TOLERANCE 5%

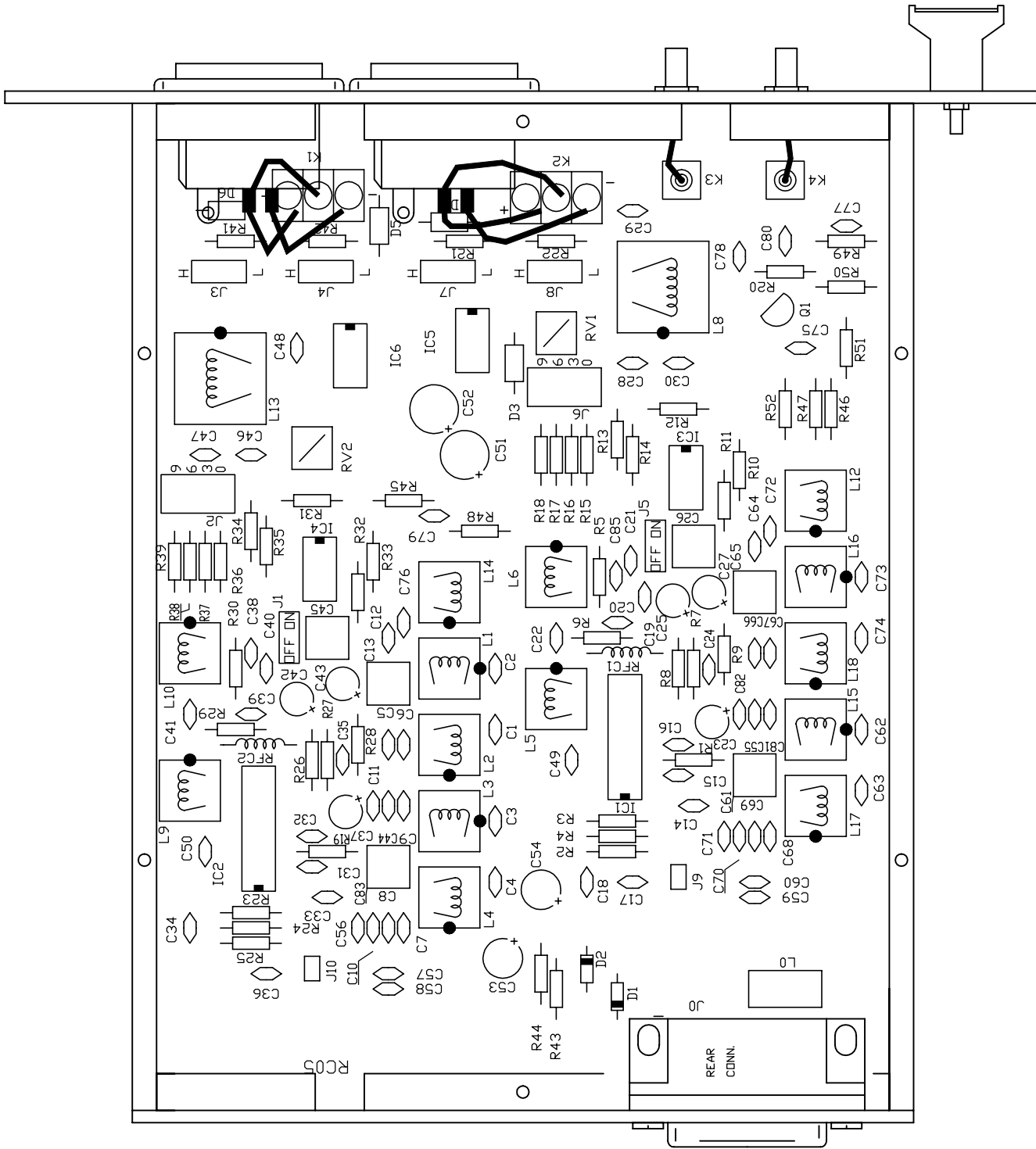
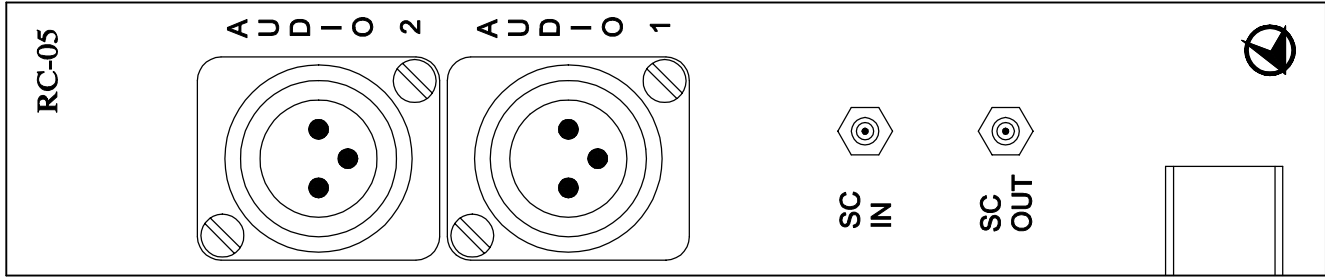

	DATE	DESCRIPTION	DRAWING CODE
	25-MAY-99	AUDIO 1/2 DEMULATOR	AD-10-CL

COMPONENT LAYOUT VALID FOR
MODULAR AND "SLIM LINE" SERIE

VIDEO SUBCARRIER SEPARATOR

TECHNICAL SPECIFICATIONS

VIDEO CHANNEL

INPUT / OUTPUT LEVEL	1 V pp
INPUT IMPEDANCE	75 OHM
INPUT RETURN LOSS	> 28 dB
VIDEO GAIN	0 dB
VIDEO BANDWIDTH	5.8 MHz @ +/- .25 dB
GROUP DELAY (0 - 5.8MHz)	< 10 nSEC
OUTPUT IMPEDANCE	75 OHM
OUTPUT RETURN LOSS	> 28 dB
AUDIO SUBCARRIER ATTENUATION	> 45 dB

SUBCARRIER

FREQUENCY BAND	6.8 MHz to 9.5 MHz
NOMINAL LEVEL	-14 dBm (70 mv eff) at 75 OHM
OUTPUT IMPEDANCE	75 OHM
OUTPUT RETURN LOSS	> 18 dB
GAIN	0 dB +/- 0.5 dB

CIRCUIT DESCRIPTION

The VIDEO SEPARATOR module has the following functions:

- it filters the base band, separating the video components from the audio and pilot subcarriers,
- it detects the pilot subcarrier and generates an alarm signal when the link S/N gets deteriorated.

The base band signal present in the BB IN connector is amplified by the video amplifier circuit including IC1 before being applied to the FL1 filter. Besides this, the amplifier must supply:

- a) an exact and constant module input impedance across the band
- b) the correct input impedance to the FL1 filter.
- c) the decoupling between filter FL1 and the subcarrier separator circuit.

The video signal is filtered by the audio subcarriers via the CF1 filter. This filter has a cut-off frequency equal to 6 MHz and is group delay equalized. The rejection for frequencies above 6.5 MHz is greater than 45 dB and the ripple of the group delay in video band is less than 10 nsec. The video signal coming out the filter is applied to a second video amplifier (IC2); the two video outputs (matched and decoupled) are presented in output to the VIDEO OUT and VIDEO AUX connectors.

The total gain of the video chain is adjusted to the correct unit value by the RV1 trimmer.

The subcarrier spectrum is taken from the base band by the high pass filter constituted by C34, C33, C32 and by the circuits LC serie RFC2, C26, C27 and RFC1, C28. The amplifier Q1, placed in the filter's output, amplifies the subcarrier spectrum to the correct level and provides the correct return loss on the SC OUT output connector.

The Pilot subcarrier is filtered by a 3 cells filter (CV1, CV2 and CV3 to associated capacities) and is converted at 455 KHz from IC4. The converted signal is filtered at narrow band from the ceramic filter CF2 and discriminated in frequency by IC4.

The output signal of the discriminator will have a noise content inversely proportional to the S/N ratio of the pilot subcarrier. This noise component is amplified (IC5A) and detected by IC5B. The DC level in output to IC5B, amplified by IC6A switches IC6B, connected as Schmitt-trigger (sending an alarm signal to pin 11 of the BUS) when its value is greater than the DC level (threshold) present on its non inverting input. At this time is also turned-off the Led PILOT, wich indicates a bad Pilot S/N.

RV2 allows the adjustment of the detector sensitivity and the threshold level of the pilot alarm.

SETUP and ADJUSTMENT PROCEDURE

INSTRUMENT REQUIRED

- Video generator (*)
- Oscilloscope or video analyzer (*)
- RF sweeper
- RF detector with XY display
- Insulated tuning screwdriver

(*) input impedance / output = 75 OHM

VIDEO GAIN ADJUSTMENT

Video Generator

Level

1 V pp

Connection

BB IN input of the module

Video Analyzer or Oscilloscope

Connection

VIDEO OUTPUT of the module

ADJUSTMENT

RV1 to have in output 1Vpp

BANDWIDTH ADJUSTMENT OF PILOT CARRIER FILTER 9023 KHz

Sweeper

Central frequency

9023 KHz

Deviation

1 MHz pp

Level

0 dBm at 75OHM

Connection

BB IN input module

RF Detector

Impedance

> 1 MOHM (with C in < 10 pf)

Connection

J1

ADJUSTMENT

CV1, CV2, CV3 to achieve a curve that will fit into the mask as shown in the diagram.

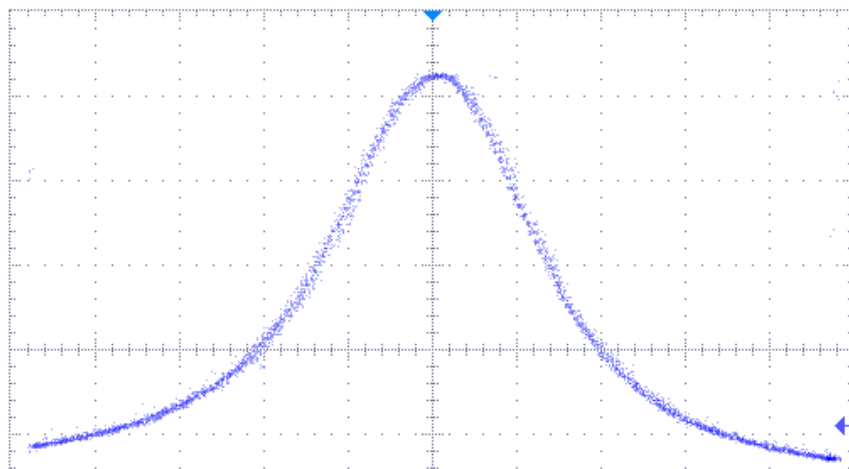

PILOT CARRIER 9023 KHz DISCRIMINATOR ADJUSTMENT

Sweeper

Central frequency

9023 KHz

Deviation

4 KHz pp

Level

-20 dBm at 75 OHM

Modulation

sinusoidal at frequency equal to 1 KHz

Connection

Input BB IN of the module

Oscilloscope

Impedance

> 1 MOHM (with C in < 10 pf)

Connection

J3

ADJUSTMENT

Tune RV2 for having a symmetrical sinusoidal wave with amplitude 8Vpp

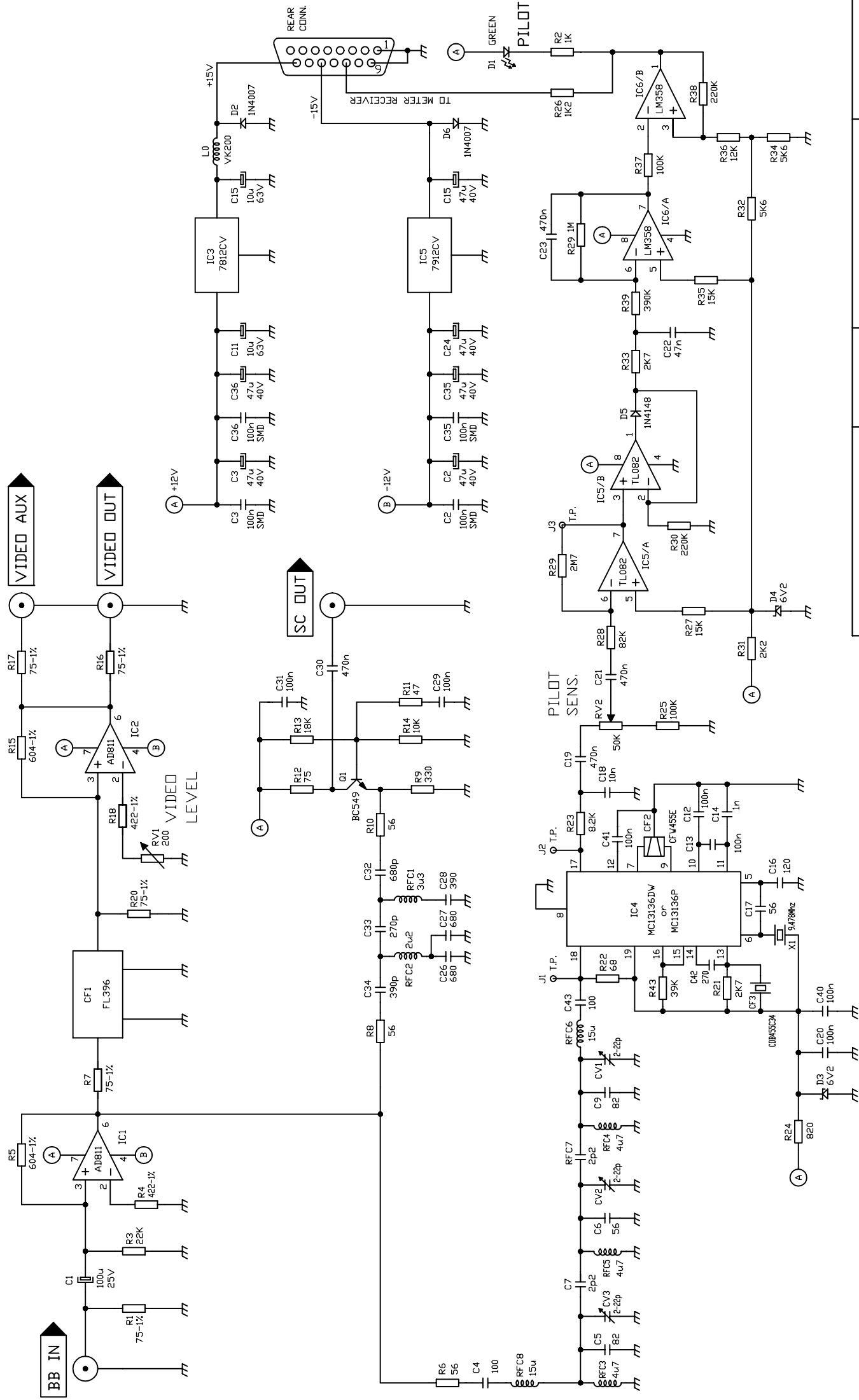

DATE	DESCRIPTION	DRAWING CODE
27-JUL-99	VIDEO SEPARATOR	VS-03-SC

ALL RESISTORS IF NOT OTHERWISE INDICATED: 1/4W - 5%
 ALL CAPACITORS IF NOT OTHERWISE INDICATED: TOLERANCE 5%

RC-07

VIDEO OUT

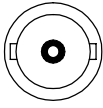

VIDEO AUX

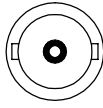

SC OUT



PILOT



BB IN

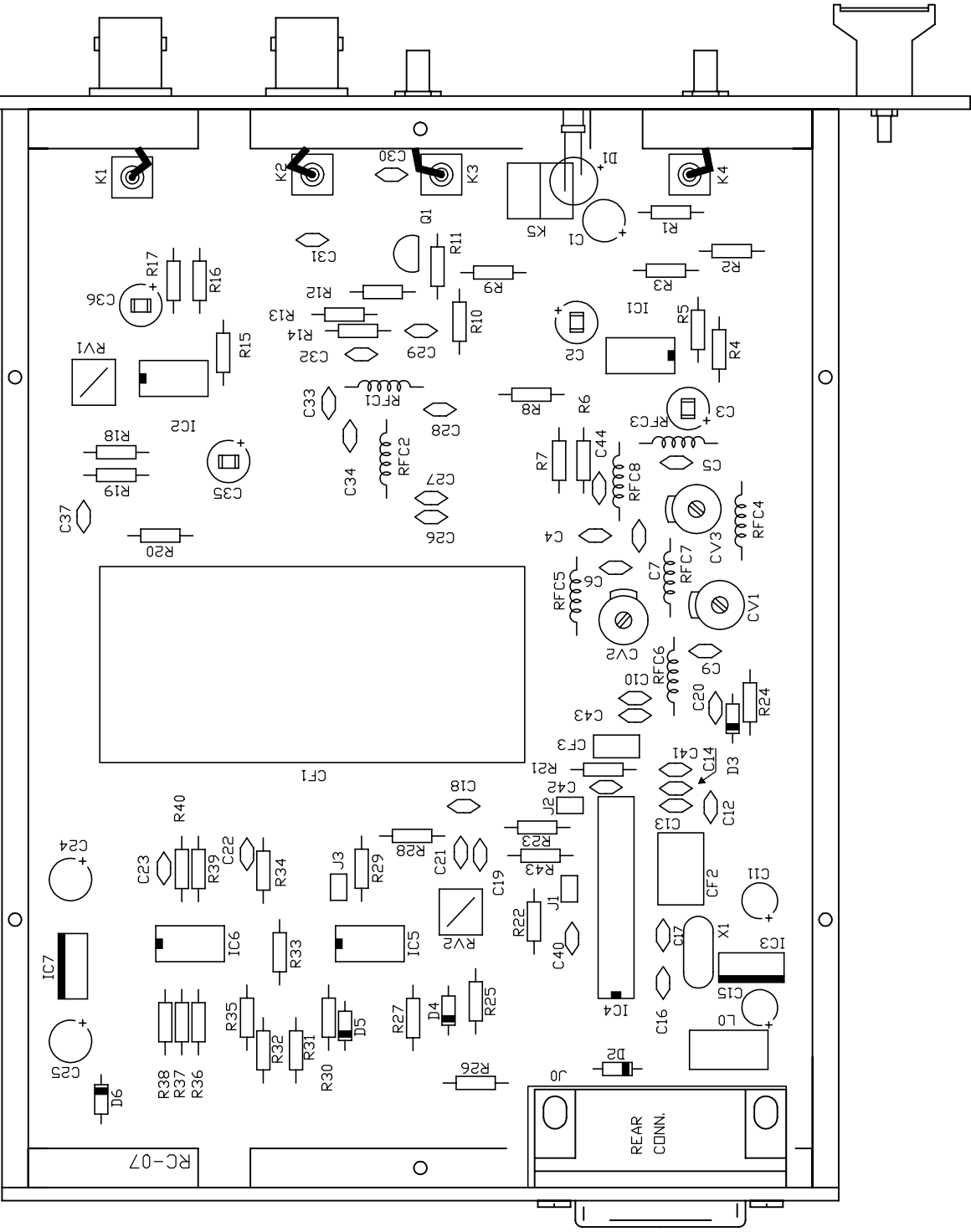

RC-07

REAR CONN.

DATE	DESCRIPTION	DRAWING CODE
12-JAN-02	VIDEO SEPARATOR	VS-06-CL



FREQUENCY DISCRIMINATOR

TECHNICAL SPECIFICATIONS

BASE BAND INPUT SPECIFICATIONS

CENTER FREQUENCY	70 MHz
INPUT LEVEL	+5 dBm +/- 1 dB
INPUT IMPEDANCE	75 OHM
INPUT RETURN LOSS	> 28 dB
NUMBER OF OUTPUT	2
ISOLATION BETWEEN OUTPUTS	> 22 dB
OUTPUT LEVEL (for $\Delta f = 8\text{MHz pp}$ at 1512 KHz)	1V pp
OUTPUT IMPEDANCE	75 OHM
OUTPUT RETURN LOSS	> 28 dB
STATIC NON LINEARITY (+/- 8 MHz)	< 0.5 %
BANDWIDTH (ripple < 1 dB pp)	40 Hz / 10 MHz
DEEMPHASIS	CCIR A 405-1
GROUP DELAY	< 1 nsec
DIFFERENTIAL GAIN	<1%
DIFFERENTIAL PHASE	<1°

CIRCUIT DESCRIPTION

The IF signal present in input of the module IF IN is amplified by Q1.

The current feedback (R52) assures a good frequency linearity, a good input match and a low output impedance.

The first limitation starts from the pair of diodes Shottky D4 & D5 connected back to back and is improved by the series circuit including the diodes D6 and D7.

The limited signal, before being sent to the discriminator circuit, is amplified by two stages equipped by Q2 and Q3. Between this stages is inserted a low pass filter (L3, C30, C31, C32) that later on must attenuate the harmonic of the IF signal generated from the limiter. The discriminator is double tuning: the IF level present on the resonant circuits constituted by L1 & CV1 (tuned at 45 MHz) and by L2 & CV2 (tuned at 95 MHz) is rectified separately from the diodes D2 & D3 and applied, in a differential way, to the input of the 1st Video amplifier IC3. The gain of this amplifier could be modified by adjusting the trimmer RV1; its purpose is setting the BASE BAND output level.

Between the 1st Video amplifier and the output video amplifier (IC4) there is inserted a deemphasis network. It is possible to exclude this network through jumpers J1 and J2, inserting a suitable attenuator on its place.

The Base Band output BB OUT and BB AUX are taken, through the resistences R1 and R2 (75 OHM), directly from the output Pin of the IC4 final Video stage.

An output impedance extremely low assures the impedance match and also the decoupling between outputs.

Moreover, the adopted configuration provides a zero output offset voltage.

SETUP and ADJUSTMENT PROCEDURE

INSTRUMENT REQUIRED

- Microwave link analyzer

DISCRIMINATOR SENSITIVITY and LINEARITY ADJUSTMENT

Generator

central frequency	70MHz
Δf	+/- 10 MHz
level	+ 5 dBm
modulation frequency	500 KHz
deviation	104 KHz
connection	IF IN input of the module

Analyzer

Connection	BB OUT output of the module
------------	-----------------------------

Jumpers

J1: deemphasis off; J2: deemphasis off

LINEARITY ADJUSTMENT

- Preset L1 and L2 in central position
- Adjust CV1 and CV2 for best linearity
- Refine the adjustment tuning L1 and L2 until the linearity curve is within a $\pm 0.5\%$

SENSITIVITY ADJUSTMENT

- Adjust the RV1 trimmer to reach a demodulated subcarrier level = -26.28 dBm.

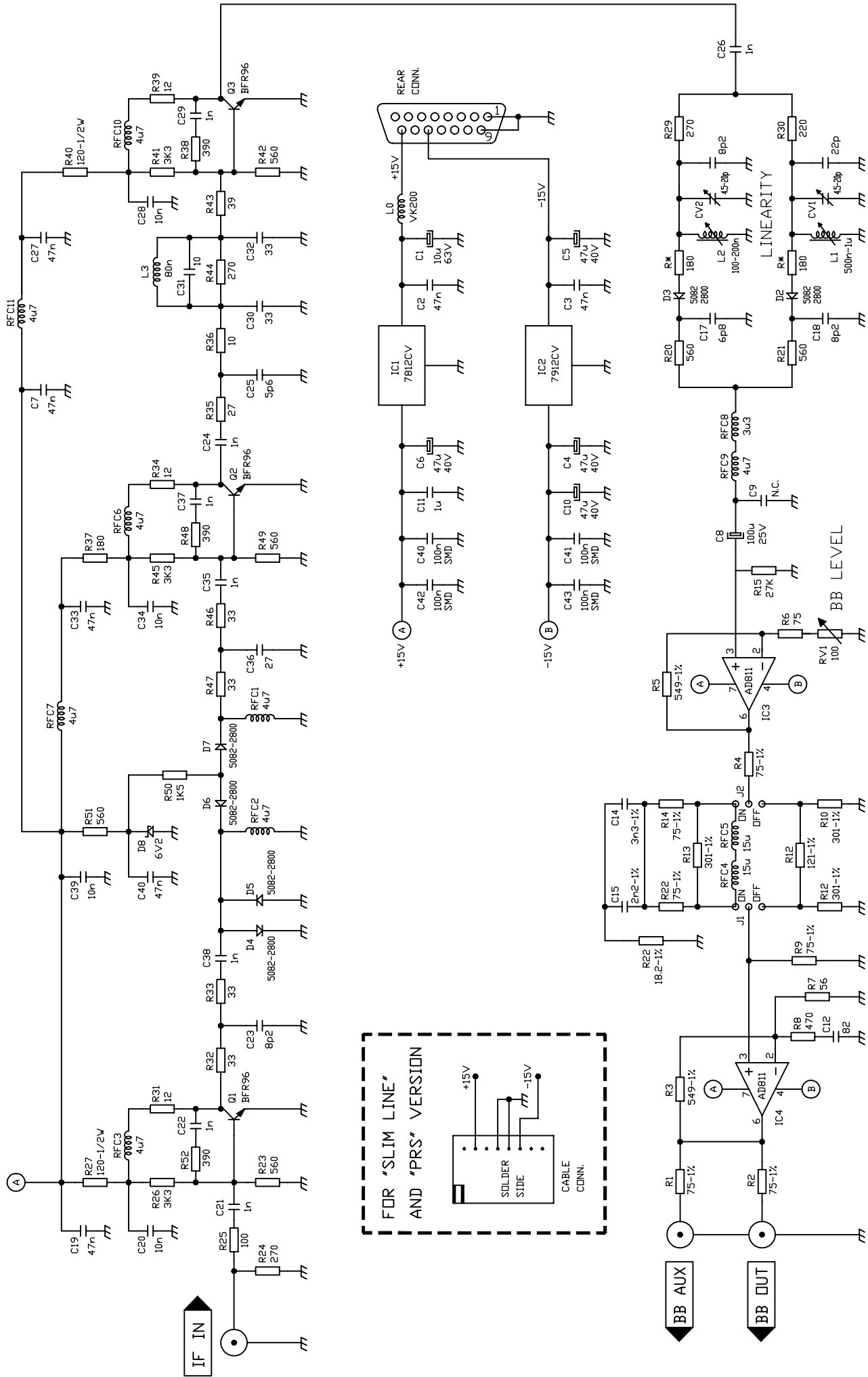

FOR "SLIM LINE"
AND "PRS" VERSION

DATE	DESCRIPTION	DRAWING CODE
29-JUN-99	IF DISCRIMINATOR	ID-03-SC



ALL RESISTORS IF NOT OTHERWISE INDICATED: 1/4W - 5%
ALL CAPACITORS IF NOT OTHERWISE INDICATED: TOLERANCE 5%

RC-08

IF IN

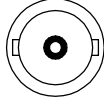

BB OUT

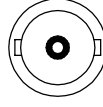

BB AUX

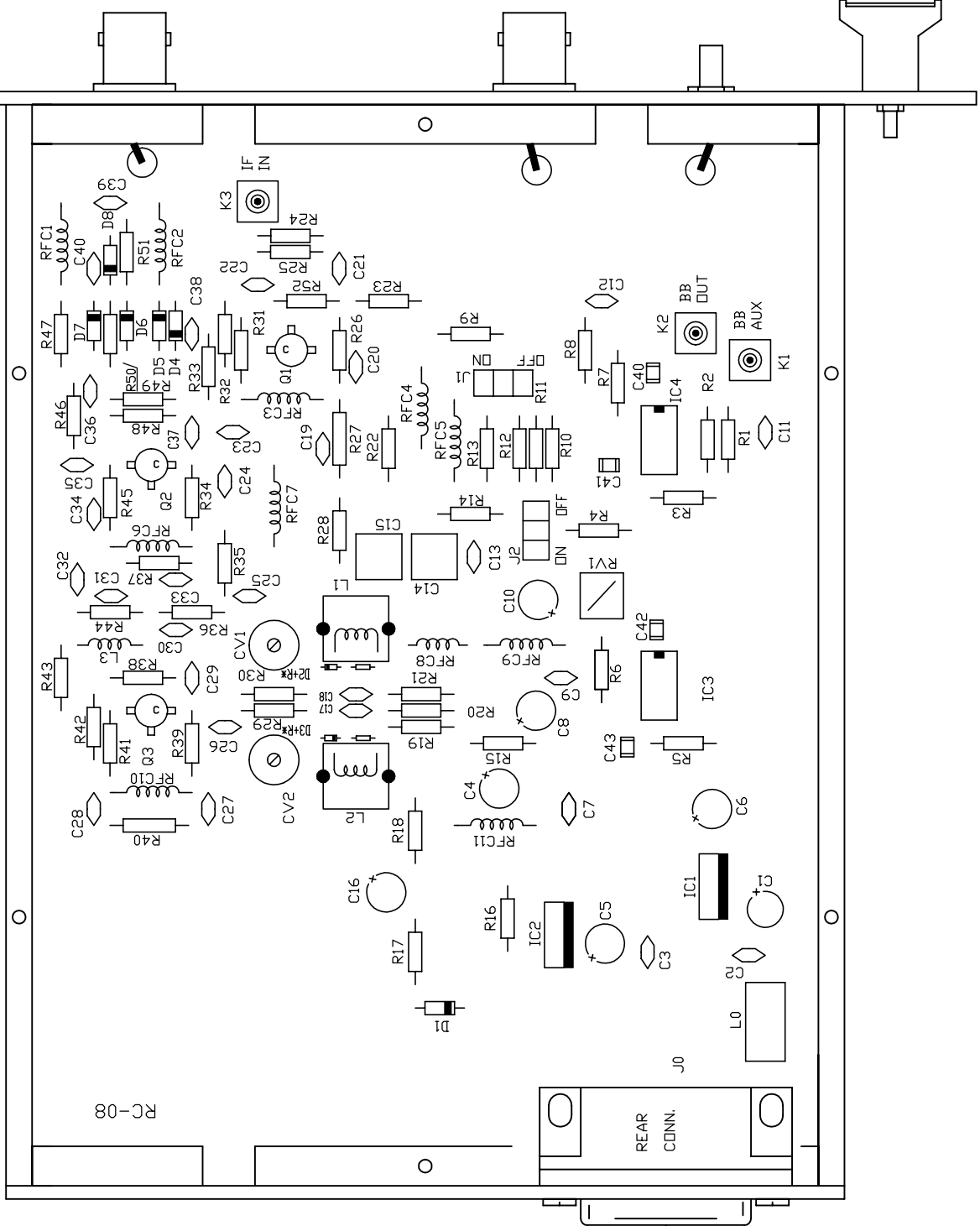

RC-08

J0

REAR CONN.

	DATE	29-JUL-99
	DESCRIPTION	IF DISCRIMINATOR
DRAWING CODE		ID-05-CL

IF - AMPLIFIER

TECHNICAL SPECIFICATIONS

CENTER FREQUENCY	70 MHz
FREQUENCY BANDWIDTH (@ 0.2dB)	30 MHz
OUTPUT LEVEL	+ 5 dBm (+/- 1 dB)
NUMBER OF OUTPUTS	3
ISOLATION BETWEEN OUTPUTS	> 22 dB
OUTPUT RETURN LOSS	> 28 dB
INPUT AGC DINAMIC RANGE	0 dBm / -55 dBm
NOISE FIGURE	< 12 dB
INPUT RETURN LOSS	> 28 dB
SQUELCH LEVEL	-49 dBm (internally adjustable from -25dBm to -55 dBm)
SQUELCH ISTERESIS	6 dB

CIRCUIT DESCRIPTION

The IF-Amplifier is constituted by five stages set one after the other. Each one is made by a transistor (Q1, Q2, Q3, Q4, Q5) with current feedback. Between the first four stages there are inserted PIN diodes attenuators (D7, D8, D9). The diodes RF resistance is controlled in order to vary the total module gain keeping the IF output level at the correct value.

Total value of the attenuation could be established manually by the trimmer RV5 while SW1 is in position MAN (see fig. Cover). RV5 can be adjusted through the front panel module.

If SW1 is in position AUTO, the attenuation is controlled automatically for having a constant IF output level (AGC). The function of AGC is executed by reading the IF level on Q4 via D13 and D14 and comparing it through IC2 with the reference level given by RV3. The IC2 output supplies the current that controls the PIN diodes resistance PIN D7, D8 and D9. The indication of the IF level input to the module is executed by IC3 sending to pin 10 of the REAR CONN a voltage proportional to the AGC signal.

IC3 provides the function of level transfer (reference given by RV1) and inverting amplifier (gain given by RV2) to obtain an output potential between 0.3V and 5V while the input signal varies from -45 dBm to 0 dBm. The Zener diodes D2, D4, D6 set in correspondant serie with D1, D3 and D5 must distribute the attenuation between the three stages when changes the input signal.

The same voltage of AGC in output to IC2 is applied to the squelch function. When the input signal is lower than the squelch expected level, the AGC exceeds the threshold value (set via RV4) of the Schmitt-trigger IC1, and jumps.

The IC2 output will low down while counter-polarizing the diodes PIN D11 & D12 set between Q4 and Q5. The IF signal will not be at the final amplification stage and the IF output will be silenced.

SETUP and ADJUSTMENT PROCEDURE

INSTRUMENTS REQUIRED

- Signal generator with output attenuator (impedance 75 OHM)
- RF voltmeter or Bolometer (impedance 75 OHM)
- DC Voltmeter

OUTPUT LEVEL ADJUSTMENT

Generator

Frequency

70 MHz

Level

-10 dBm

Connection

IF-IN input of the module

RF Voltmeter

Connection

IF-OUT output of the module.

AGC switch

auto

ADJUSTMENT

Set RV3 until you obtain an output level reading of +5 dBm at the RF voltmeter.

SQUELCH LEVEL ADJUSTMENT

Generator

Frequency

70 MHz

Level

-49 dBm

Connection

IF-IN input of the module

AGC switch

auto

ADJUSTMENT

- Rotate RV4 until you obtain an IF output
- Rotate RV4 counter-clockwise to the minimum value (threshold) to get a silence IF output.

LEVEL INSTRUMENT ADJUSTMENT

Generator

Frequency

70 MHz

Level

according to what is indicated in the adjustment procedure

Connection

IF IN input

RF Voltmeter

Connection

Pin 1 of IC3

AGC switch

Auto

ADJUSTMENT

- Set the generator level at -45 Dbm
- Rotate RV1 to have an indication of 0.3V in the voltmeter
- Set the generator level at 0 dBm.
- Rotate RV2 for having 5V in the voltmeter
- Repeat this sequence until the trimmers retouch are not requested.

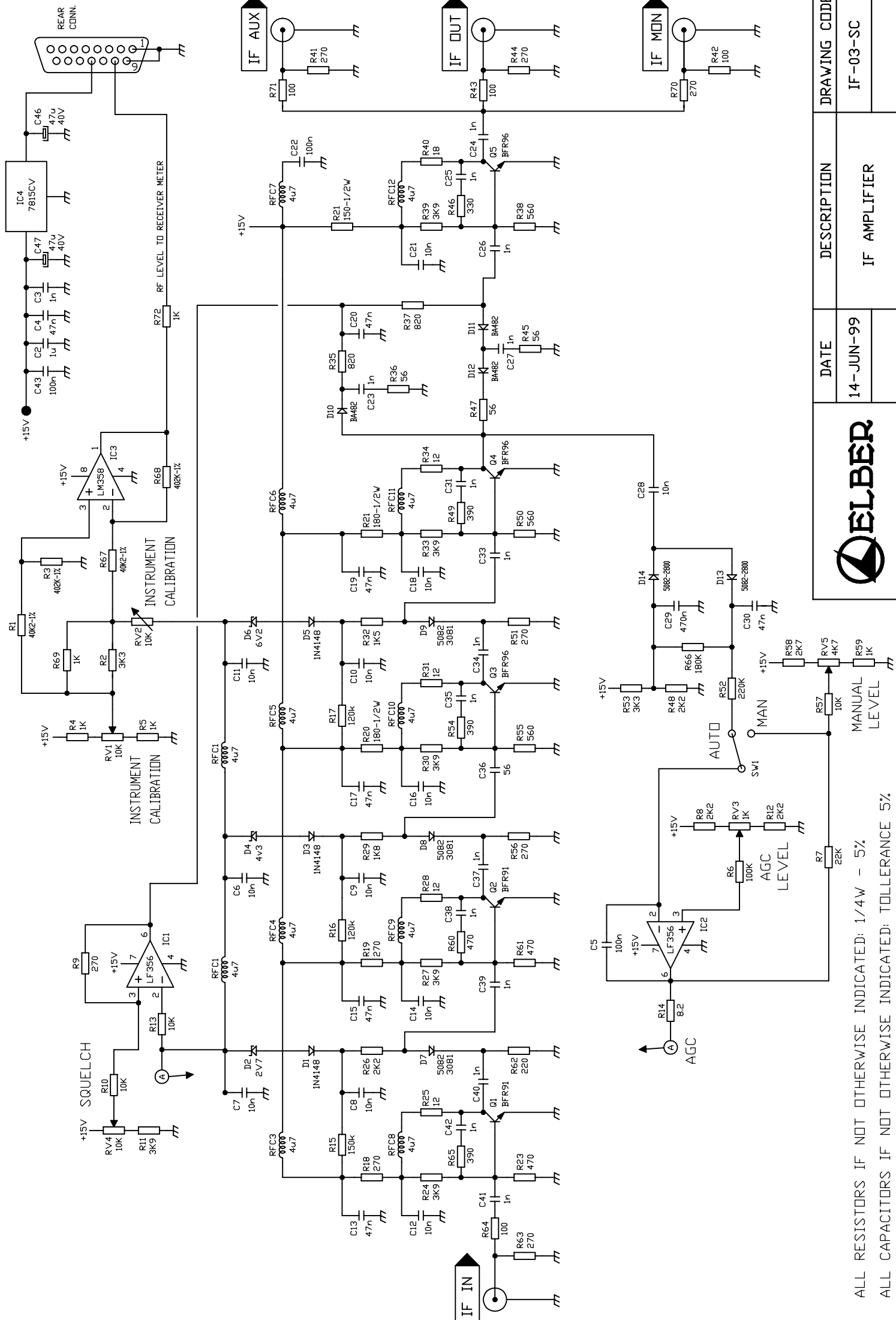

DRAWING CODE	IF-03-SC
DESCRIPTION	IF AMPLIFIER
DATE	14-JUN-99

ALL RESISTORS IF NOT OTHERWISE INDICATED: 1/4W - 5%
 ALL CAPACITORS IF NOT OTHERWISE INDICATED: TOLERANCE 5%

RC-20

IF AUX

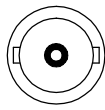

IF OUT



IF MON

man level ⊕

IF IN

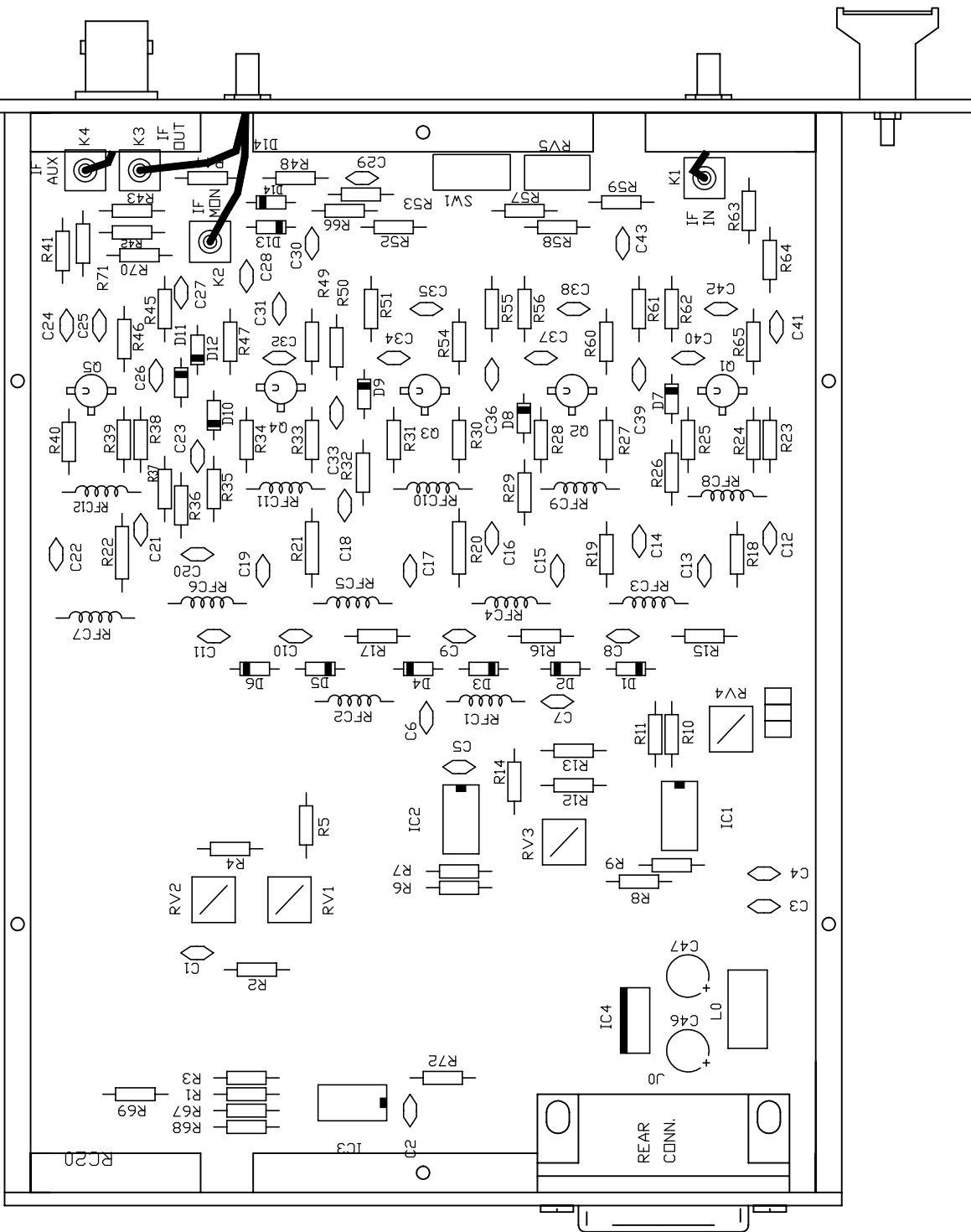

DATE

14-JUN-99

DESCRIPTION

IF AMPLIFIER

DRAWING CODE

IF-05-CL



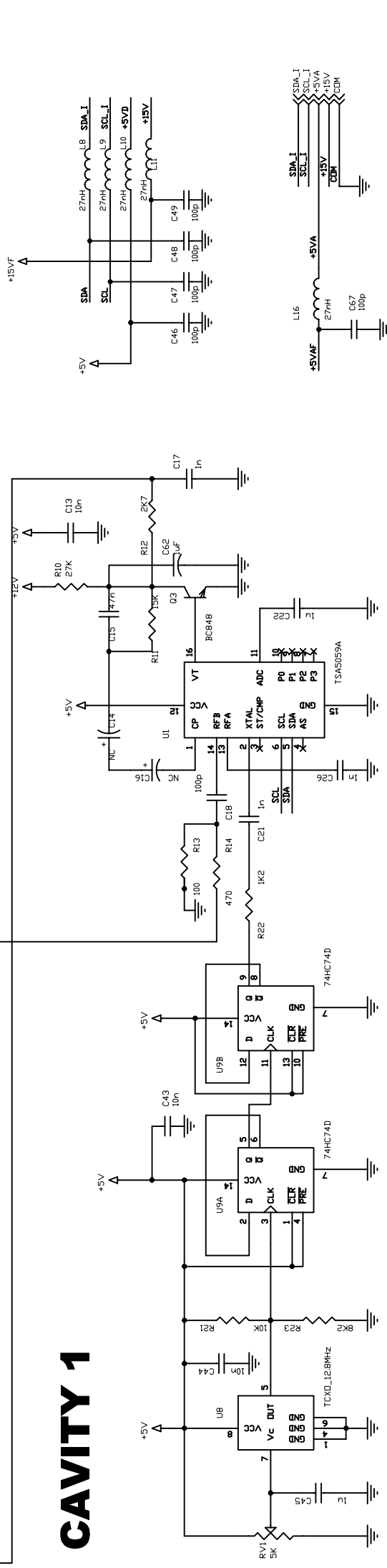
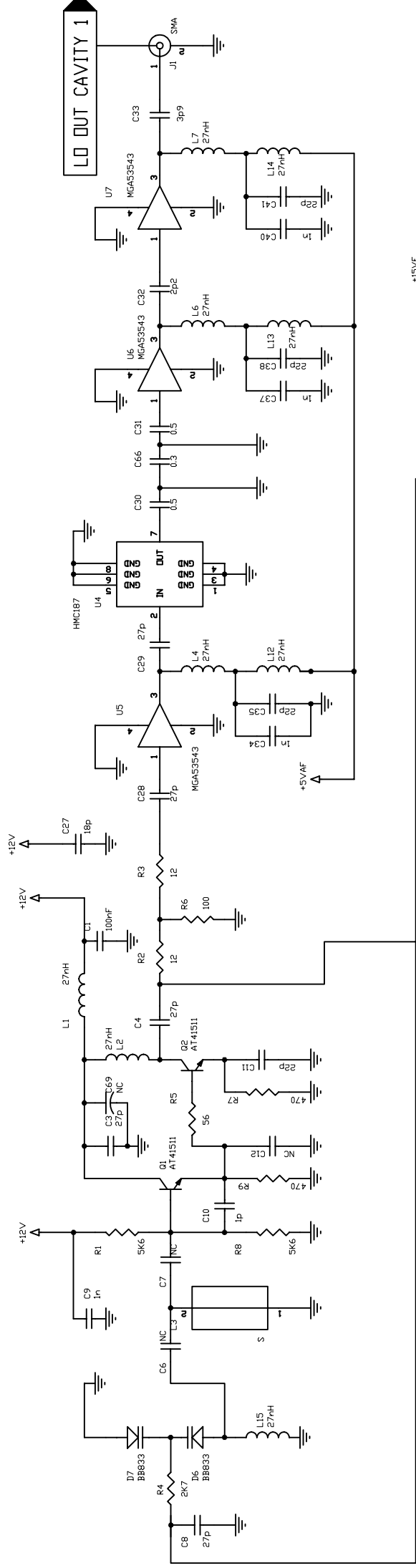

Component	Value	Frequency
C6	1pF	4.5-6.25 AND 9GHZ - 12Ghz
C7	0.5pF	6.25-7.75 AND 12.5GHZ - 15.5Ghz
C10	3.3pF	

Component	Value	Description	Drawing Code
C6	1pF	N.C.	LD-23-SC
C7	0.5pF	0.3pF	
C10	3.3pF	N.C.	
DATE		14-JAN-05	SYNTHESIZE OSCILLATOR

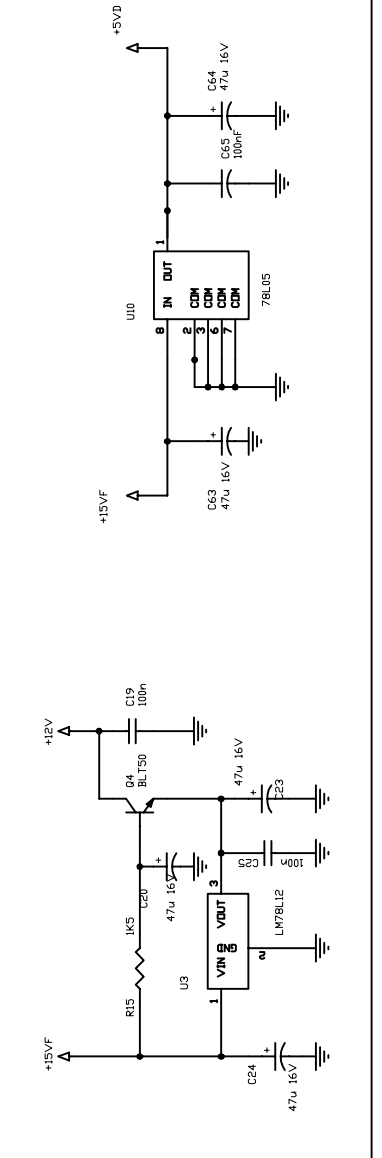

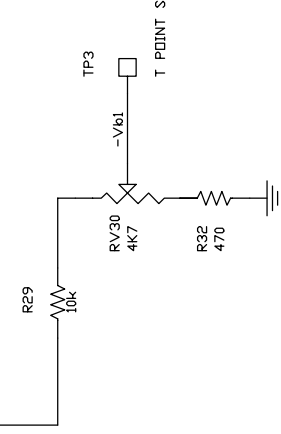
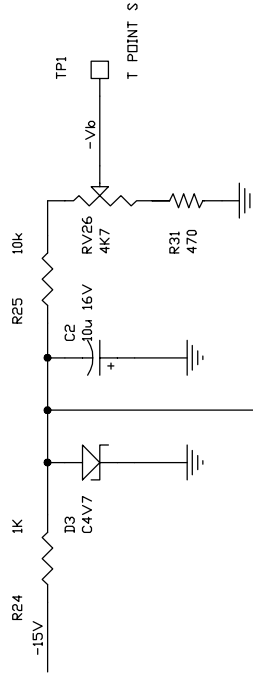
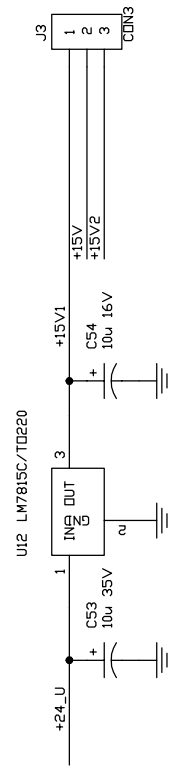
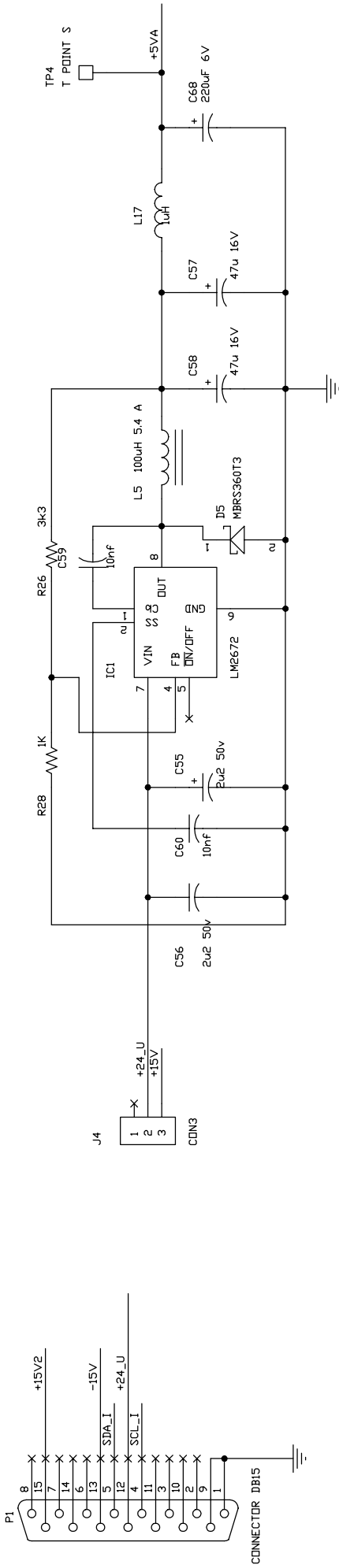

DATE
19-OCT-05

DESCRIPTION
LOCAL OSCILLATOR

DRAWING CODE
LO-31-SC

CAVITY 2 (ONLY FOR LO OUT=4.5-6.25GHZ)

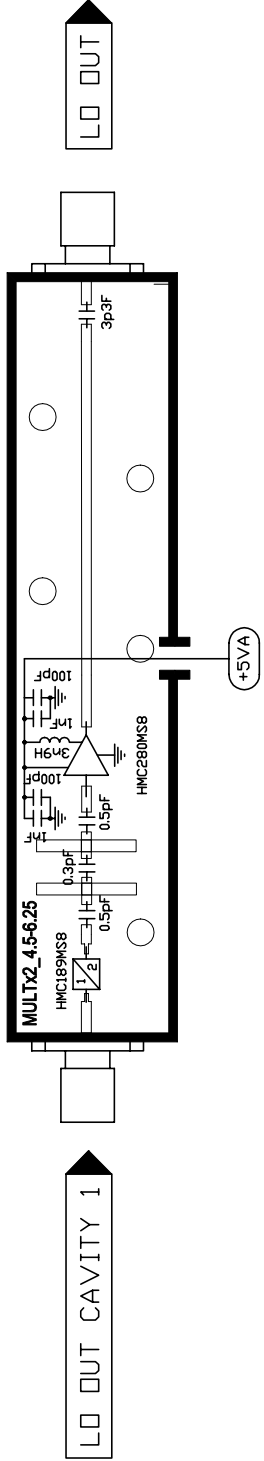

CAVITY 2 (ONLY FOR LO OUT=6.25-7.75GHZ)

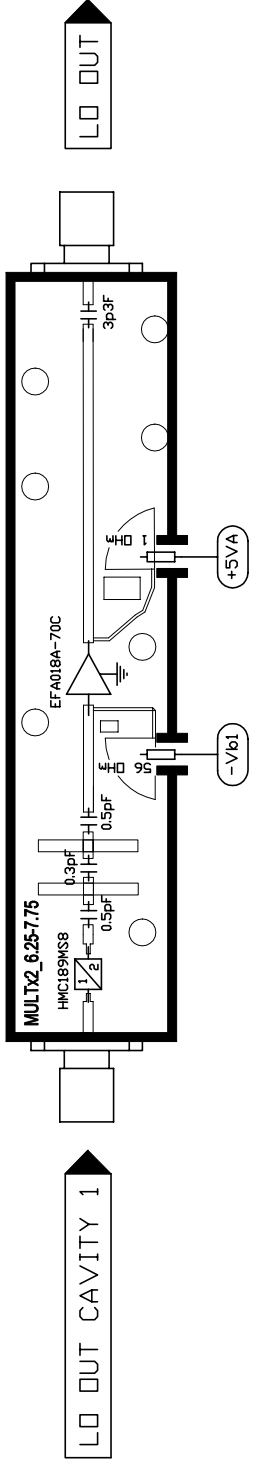

CAVITY 2 (ONLY FOR LO OUT=9-12.5GHZ)

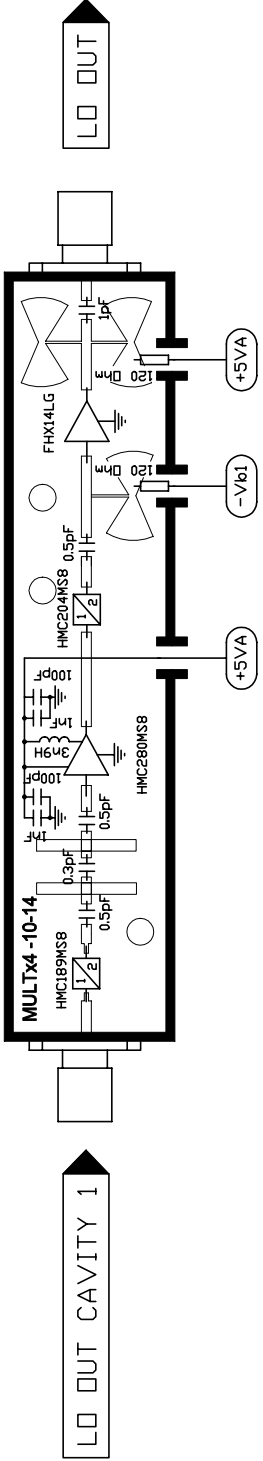

CAVITY 2 (ONLY FOR LO OUT=12.5-15.5GHZ)

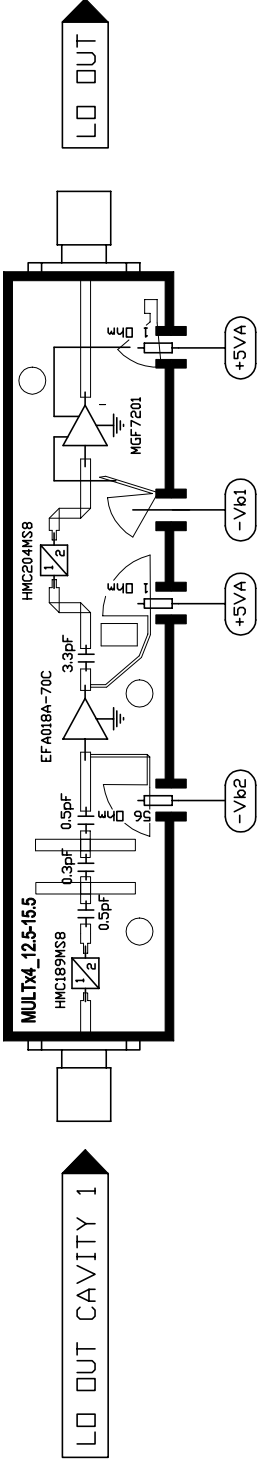

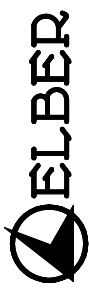
		DATE	DESCRIPTION	DRAWING CODE
		14-JAN-05	SYNTHESIZE OSCILLATOR	LD-22-SC

RTC-31

LO OUT

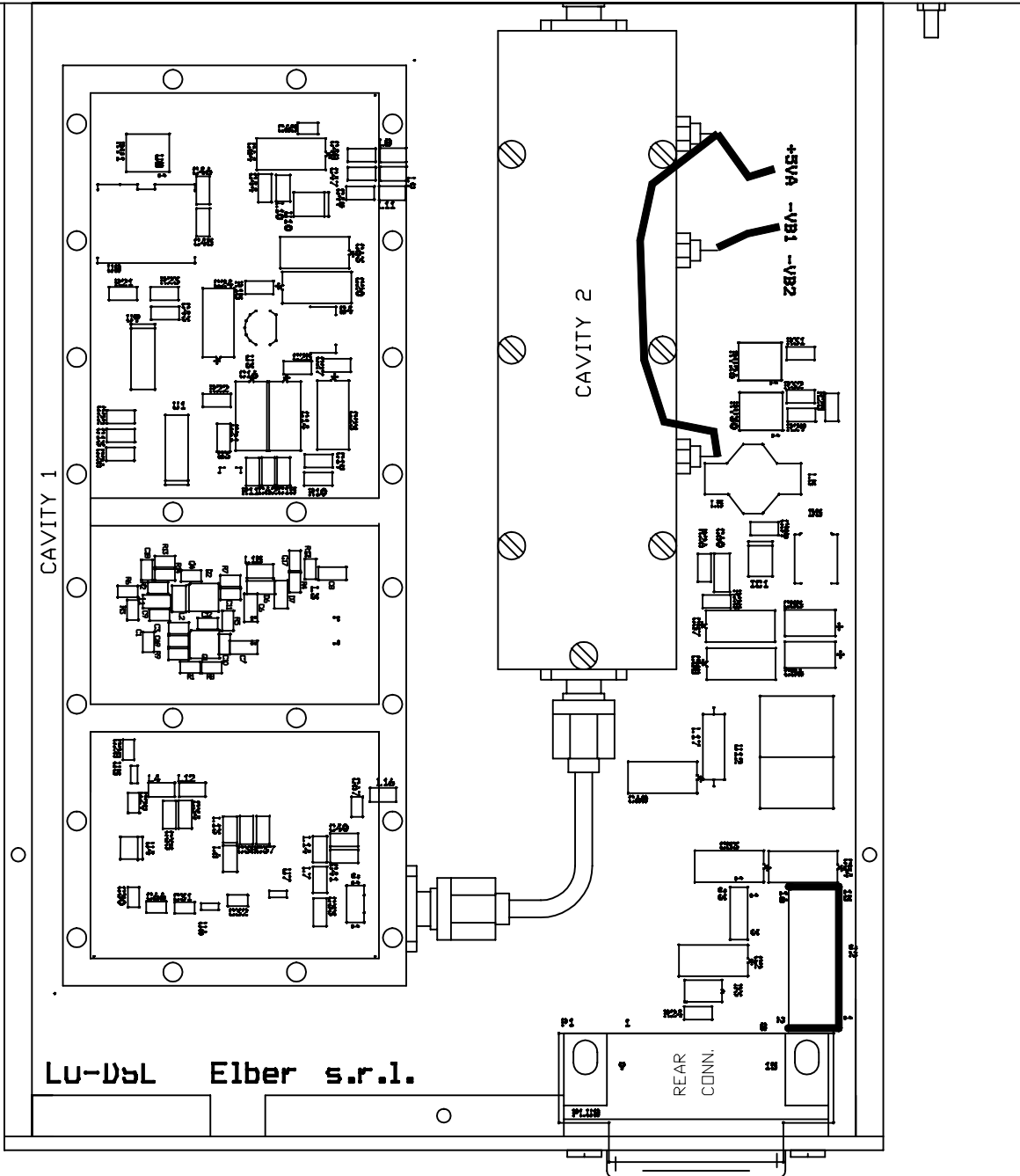

LU-D5L Elber s.r.l.

		DATE	14-JAN-05
		DESCRIPTION	SYNTHESIZE OSCILLATOR 9-12.5 GHZ
DRAWING CODE		LD-25-CL	

DOWN CONVERTER 10-15 GHz

TECHNICAL SPECIFICATIONS

FREQUENCY BAND	10200 / 10700 MHz 10700 / 11700 MHz 11700 / 12400 MHz 12400 / 12700 MHz 12700 / 13200 MHz 14200 / 14600 MHz 14600 / 15200 MHz
NOISE FIGURE	< 4 dB
INPUT RETURN LOSS	<10 dB
INPUT CONNECTOR	SMA Female
GAIN	30 dB IF OUT (filtered) 25 dB IF MON (monitor)
OUTPUT CONNECTOR	BNC Female (IF OUT monitor) SMB Female (IF OUT filtered)
OUTPUT RETURN LOSS	> 28 dB
GROUP DELAY	< 2 nsec (62 MHz - 78 MHz)
AMPLITUDE FREQUENCY FLATNESS	< 0.2 dB (60 MHz - 80 MHz)
SELECTIVITY	see diagram

CIRCUIT DESCRIPTION

The frequency conversion happens in the DOWN CONVERTER module. This module contains a RF preamplifier equipped with FET HEMT. The amplified microwave signal reaches the mixer through a filter notch and a Drop-in isolator. The filter notch uses a dielectric resonator and is adjusted at the receiver image frequency, that is being changed 140 MHz regarding to the working frequency.

The mixer is balanced. The conversion product at 70 MHz, in output to the mixer, is amplified at a large band of Q1 and Q2. Previous attenuation, the preamplifier output is sent to the monitor output IF OUT (monitor) and to the IF filter.

The IF filter is constituted by a passive equalization section at two cells (including L2, L4 and L1, L3) and a high pass elliptic filter (including L7, L8 and L9) following a low pass filter (including L12, L11 and L10) of the same type.

The equalization section must correct the RF input filter & IF filter group delay.

The signal in output to the filter is amplified by Q3 before being applied to the IF OUT output (filtered).

SETUP and ADJUSTMENT PROCEDURE

INSTRUMENTATION REQUIRED

Microwave link generator constituted by:
 - Generator 70 MHz / Impedence 75 OHM
 - Analyzer 70 MHz / Impedence 75 OHM
 - Voltmeter DC

FILTER and IF EQUALIZER ADJUSTMENT

Generator

central frequency

70 MHz

Δf

according to adjustment norms.

Level

-10 dBm

Connection

TP1 through serie of R=75 OHM and C=1nF

Analyzer

Connection

Output IF OUT of the module

ADJUSTMENT

- Set the generator Δf at +/-30 MHz
- Adjust L8 to carry the notch at 55,4 MHz
- Adjust L11 to carry the notch at 97 MHz
- Adjust L2 and L4 (1° equalizer) for minimum attenuation in the band 58 MHz – 82 MHz
- Adjust L1 and L3 (2° equalizer) for minimum attenuation in the band 58 MHz – 82 MHz
- Adjust L7, L9, L10, L12 for the minimum ripple and maximum output in the band 58 MHz – 82 MHz
- Set generator Δf at +/-10,5 MHz
- Adjust L2, L4 (1° equalizer) and L1, L3 (2° equalizer) to obtain a group delay answer as shown in the picture.
- Adjust L12, L10 (low pass section) and L7, L9 (high pass section) to obtain a answer in amplitude as shown in the picture.
- Repeat the last two steps alternated until both curves are satisfactory **at the same time**.

RF PREAMPLIFIER BIAS ADJUSTMENT

Voltmeter DC

Connection Positive terminal at TP2
 Negative terminal to ground

ADJUSTMENT

Set RV2 until reading 190mV on TP2

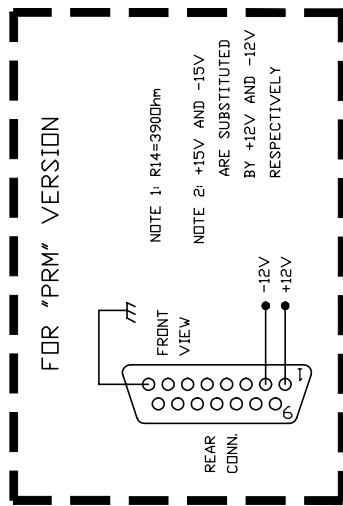
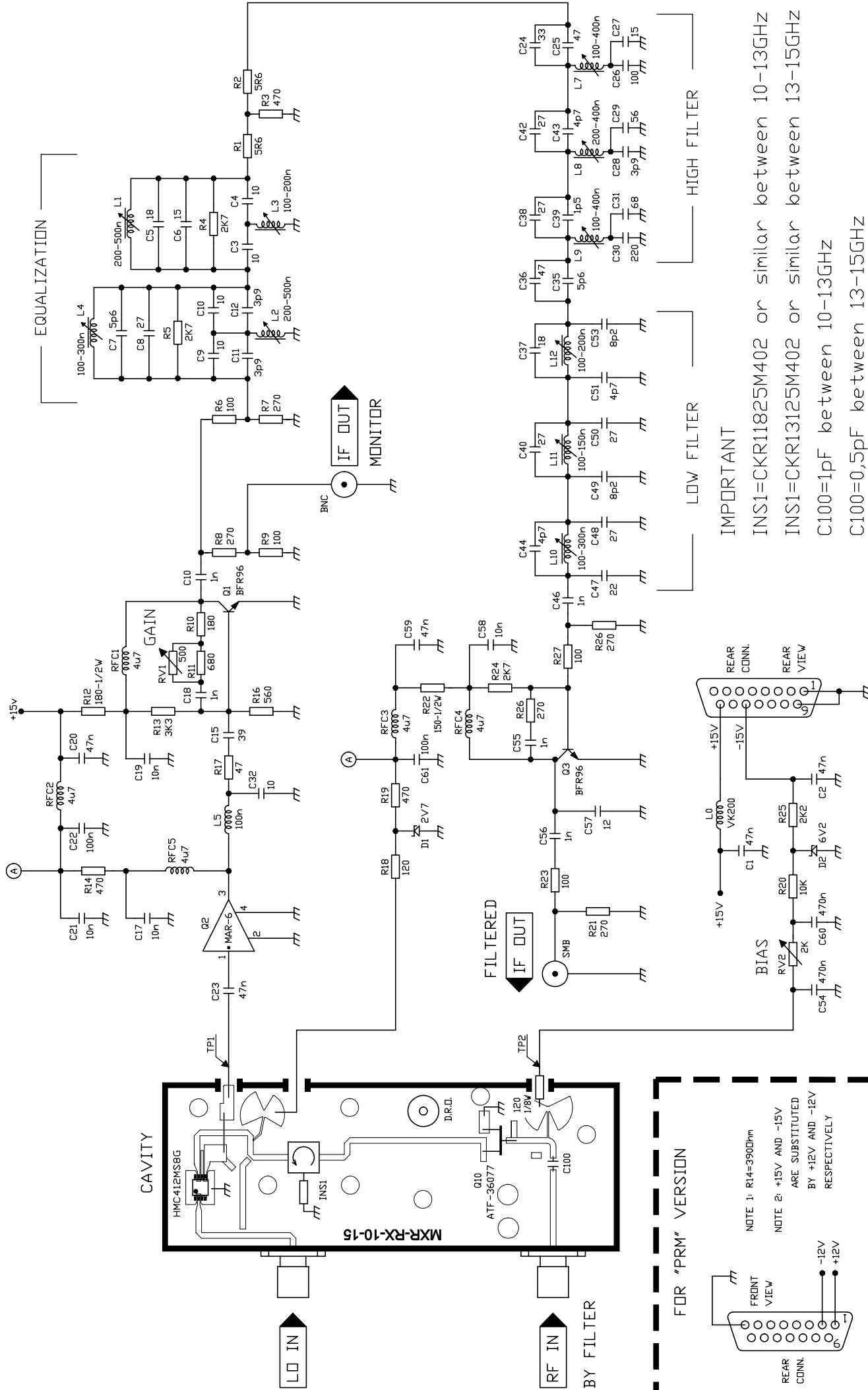

IMPORTANT
 INS1=CKR11825M402 or similar between 10-13GHZ
 INS1=CKR13125M402 or similar between 13-15GHZ
 C100=1pF between 10-13GHZ
 C100=0.5pF between 13-15GHZ

DATE	DESCRIPTION	DRAWING CODE
02-FEB-03	DOWN CONVERTER 10-15GHZ	DW-22-SC



ALL RESISTORS IF NOT OTHERWISE INDICATED: 1/4W - 5%
 ALL CAPACITORS IF NOT OTHERWISE INDICATED: TOLERANCE 5%

RC-22

RF IN



LO IN



IF MON
OUT

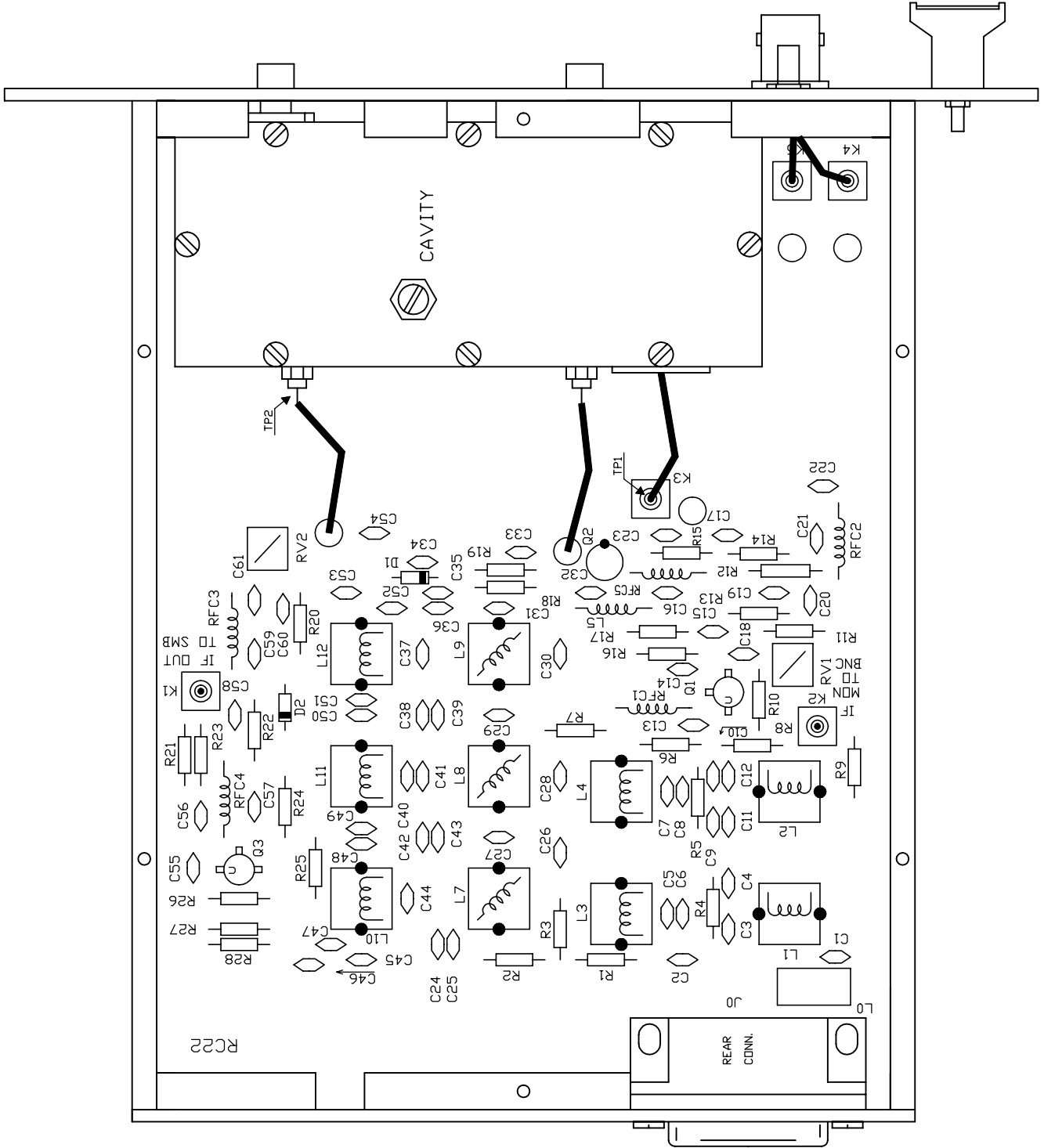

DATE
20-MAY-99

DESCRIPTION
DOWN CONVERTER
10-11-12-13GHZ

DRAWING CODE
DW-04-CL



SUPPLY

TECHNICAL SPECIFICATIONS

INPUT	230V AC +/-10% or 110V AC +/-5% 24V /30V DC negative to ground
INPUT SELECTION	automatic
OUTPUT	+24V @ 1A ; +15V @ 1A ; -15V @ 300 mA
PROTECTIONS	
AC INPUT	1.6A T fuse
DC INPUT	8A fuse
OUTPUTS	all outputs are electronically protected against short circuits towards ground.

CIRCUIT DESCRIPTION

The supply input voltage could be constituted by the rectified output of the main transformer or by a continuous nominal voltage source at 24 V.

The selection occurs simply on the basis of the level arriving to the diode bridges D3 and D4. This last ones will also prevent any reciprocal load.

The 24V voltage is generated by a linear stabilizer (IC2) fed by the voltage supplied by a CC/CC step up voltage converter (IC4).

The 15V voltage is obtained from the input continuous voltage via a voltage linear regulator (IC1).

The negative voltage -15V is produced by the switching supply made by IC3 and Q1.

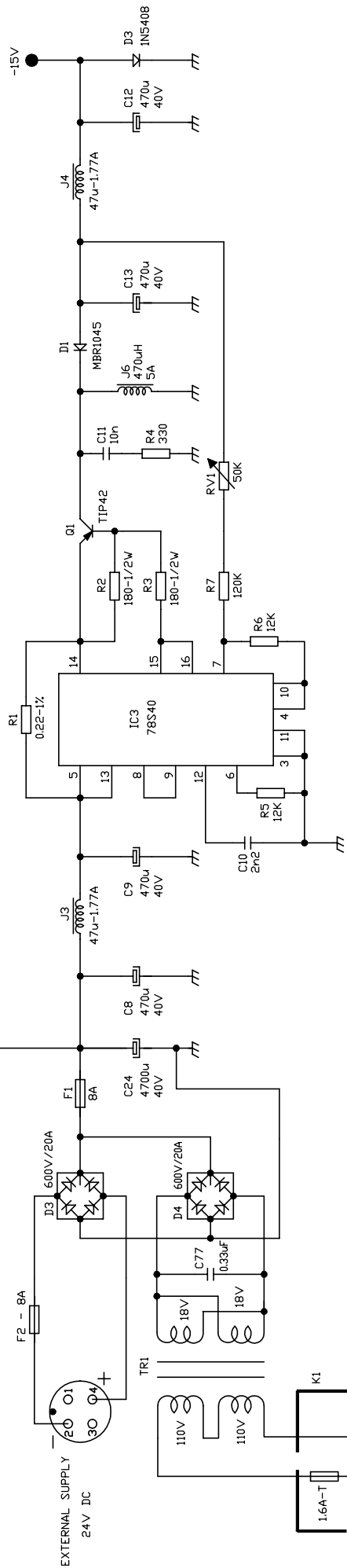
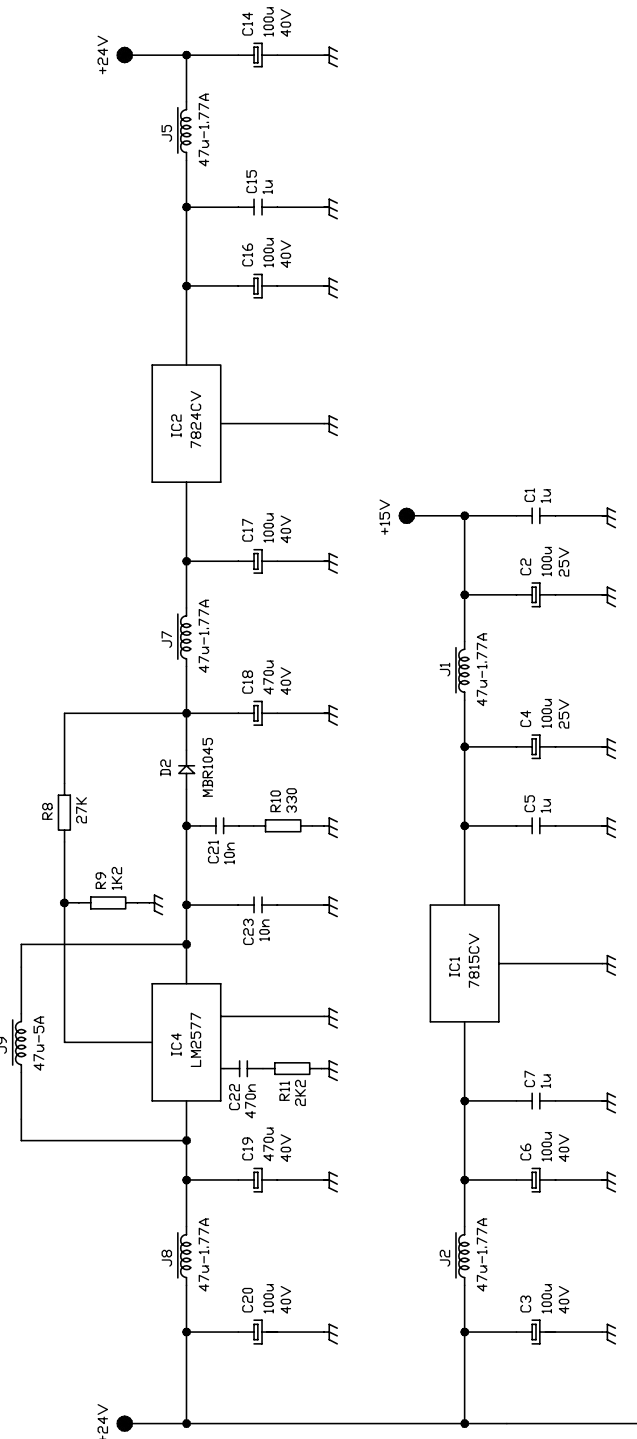
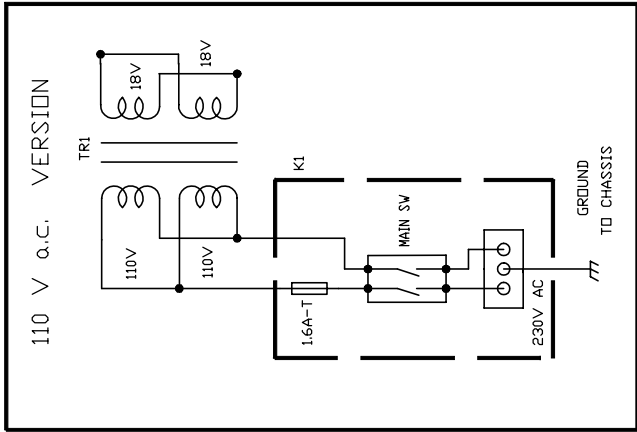

ALL RESISTORS IF NOT OTHERWISE INDICATED: 1/4W - 5%
 ALL CAPACITORS IF NOT OTHERWISE INDICATED: TOLERANCE 5%



DATE
03-JUL-99

DESCRIPTION
POWER SUPPLY TMC

DRAWING CODE
PS-03-SC

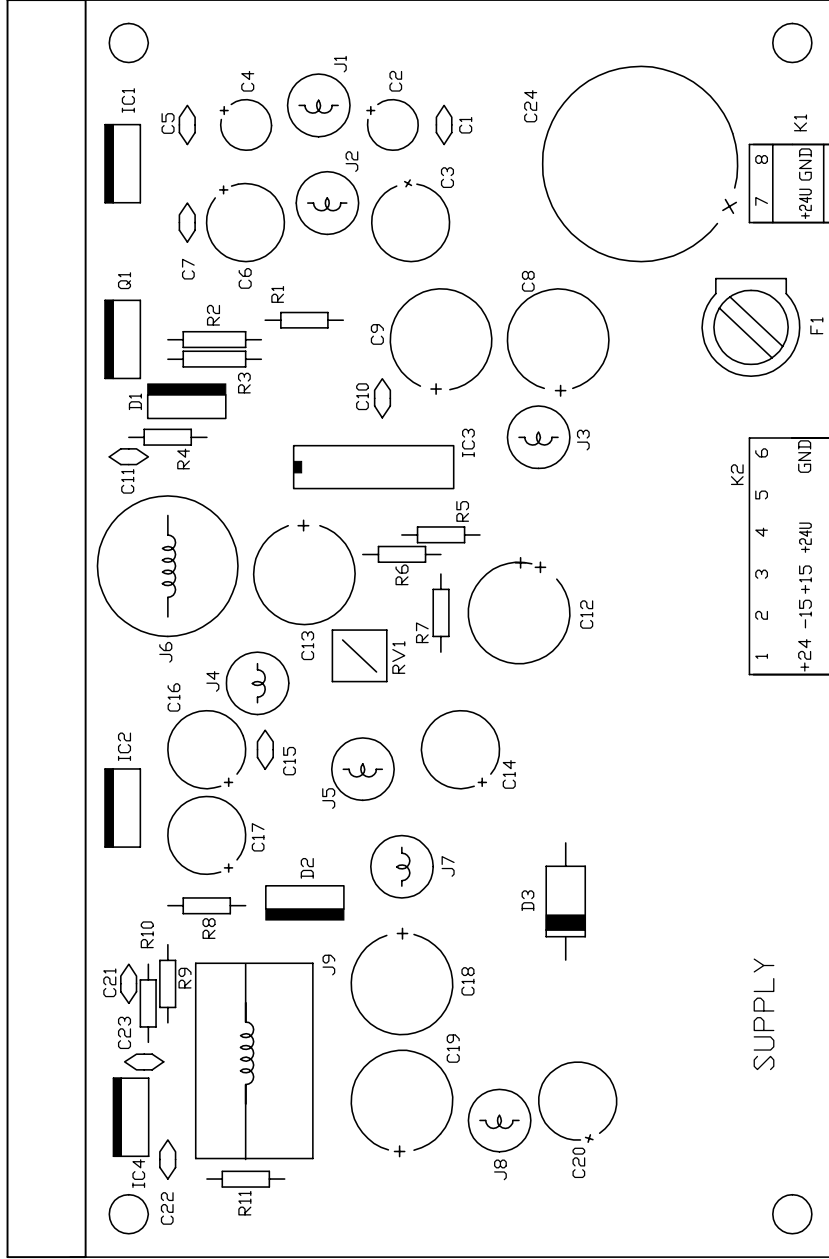

BLACK
RED

WHITE

YELLOW
BLUE
VIOLET
RED

7	8
+24U	GND
K1	

1	2	3	4	5	6
+24	-15	+15	+24U	GND	GND
K2					

SUPPLY

	DATE	DESCRIPTION	DRAWING CODE
	07-JUN-99	POWER SUPPLY TMC STABILIZATION BOARD	PS-06-CL

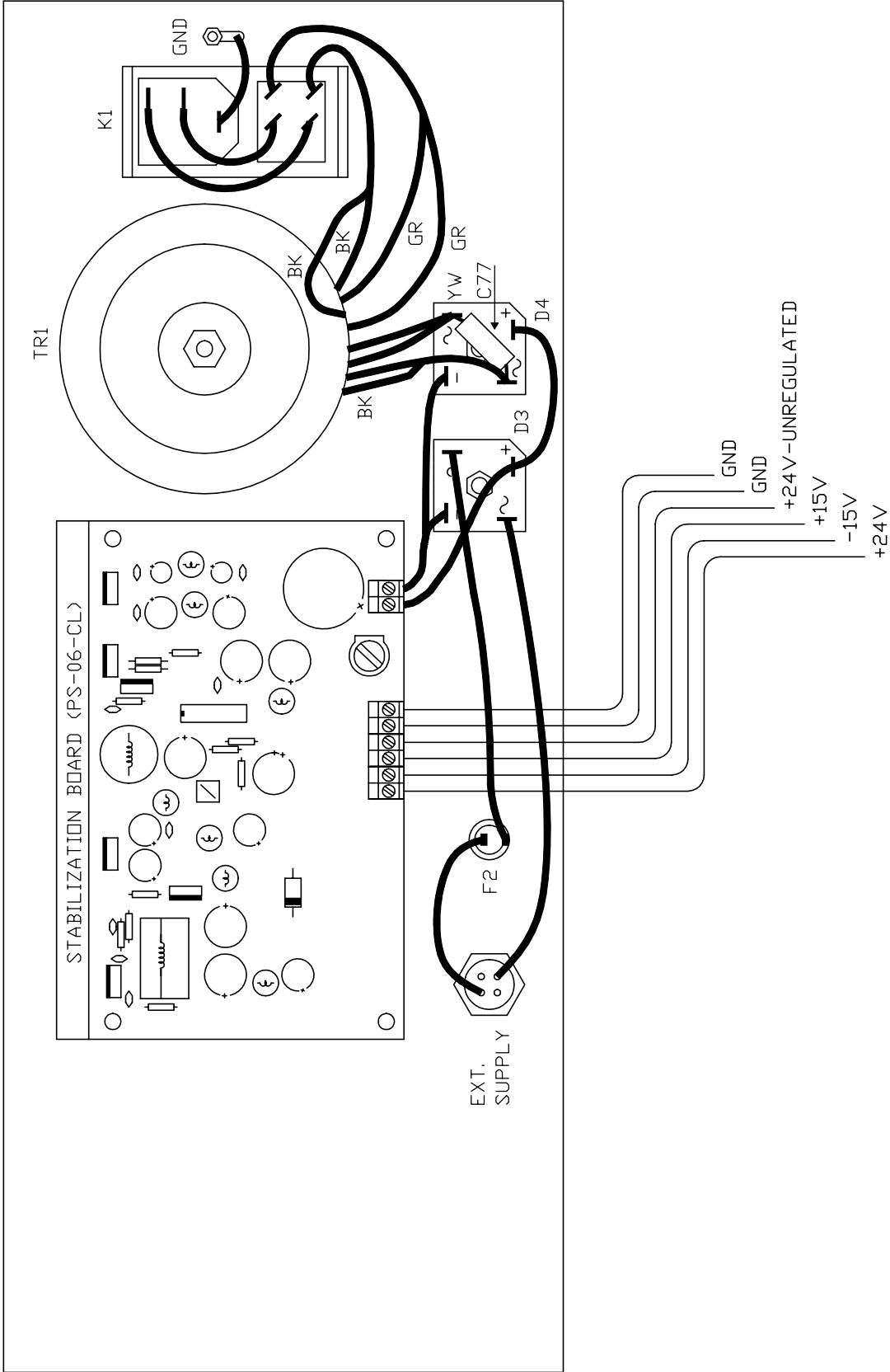

DATE	DESCRIPTION	DRAWING CODE
15-JUN-99	POWER SUPPLY TMC 110V - ASSY PANEL	PS-07-CL

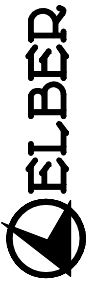

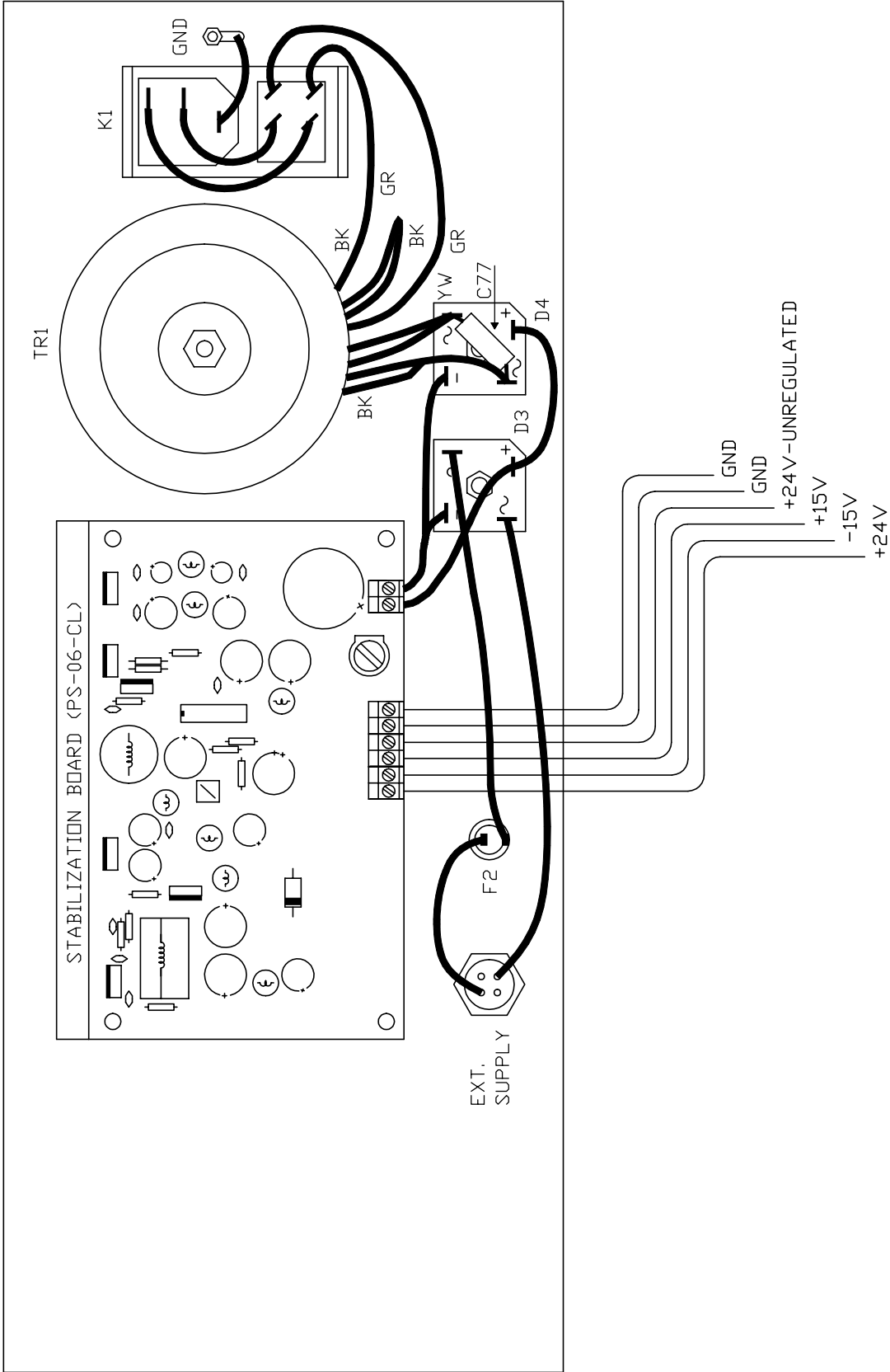

DATE	DESCRIPTION	DRAWING CODE
15-JUN-99	POWER SUPPLY TMC	PS-05-CL
	230V - ASSY PANEL	

